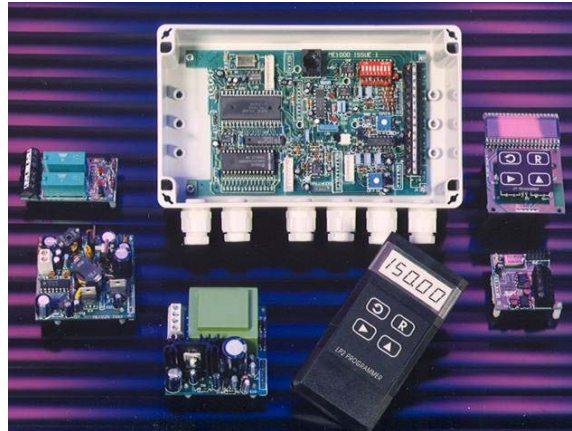


# LCA15

## Weighing Amplifier/Digitiser Module



[www.mantracourt.co.uk](http://www.mantracourt.co.uk)

User Manual

**ME** mantracourt

# Quick Guide

## Front Panel Guide

- ▶ Used to scroll through and change the set up data by displaying mnemonics for each configurable parameter, followed by the appropriate data. When in programming mode it should be noted that the first digit in the display may not be visible, but the program indicator --- will be flashing to indicate that the instrument is in programming mode, even though no digits can be seen to be flashing---
- Ⓜ Selects the display digit required. Selection value is indicated by a flashing digit and flashing program indicator.
- ▲ Increments each selected display digit 0-9. Pressing the **R** key under programming conditions will display the leading digit as either 1, -1, or a blank display for zero.
- R** Resets the display to the input variable and enters new data in the LCA15 memory. Returns the display to the current value after Hold. If during the programming sequence, selection is not completed, the display will revert to the input variable after 2 minutes.

## The Configurable Parameters

A series of parameters or programmable functions are provided in the LCA15.

These parameters are included as constants in the LCA15 database and are accessed and checked via the programmer keypad or the communications port.

New data, when entered, overwrites previous entries when the **R** key is pressed unless the EEPROM has been disabled via the communications port.

## Password Protection

A 4 digit password number must be entered. The number is accessed when 'PASS' is displayed. At this point, it is necessary to enter either the factory set number (contact supplier) in digit positions 2-5, or the password number specifically ordered by the customer.

## Configurable Parameters

Code	Value	Function
PASS	±19999	Security Password. Correct value required to proceed further.
SP1	±19999	Set Point 1 'desired' trip value of output 1
IF1	±19999	In-Flight compensation for SP1. Relay 1 operates at = SP1 - IF1
SP2	±19999	Set Point 2 'desired' trip value of output 2
IF2	±19999	In-Flight compensation for SP2. Relay 2 operates at = SP2 - IF2
HYS	0-19999	Hysteresis amount applied to SP1 and SP2
OA	0-31	Output Action. Relays energise or de-energise above SP level. Analogue output normal or inverted, and latching
CALL	±19999	Calibration Low. Display value for low calibration point(Must be less than CALH)
CALH	±19999	Calibration High. Display value for high calibration point Note: When CALH = 0, the LCA15 display scaling is -19999 to +19999
At	±19999	Auto Tare value
dA	0-7	Display Averaging 1 to 64 standard display updates
	8-15	Display Averaging 1 to 64 display updates for peak hold
OPL	±19999	Output Low (minimum) Display point for minimum analogue output
OPH	±19999	Output High (maximum) Display point for maximum analogue output

dP	Decimal Point	Code	dP Position	
		0	19999	To set the required position of the decimal point on the display.
		1	1.9999	
		2	19.999	
		3	199.99	
		4	1999.9	
		5	19999.	
Cp	0-129	Comms Protocol 0 to 127 = Printer 128 = 'Fast' MANTRABUS 129 = 'ASCII'		
SdSt	0-254	Serial Device Station Number. This is the address code for each LCA15 when the communications port is used.		
OR				
LAb	0-255	Selects the desired label for the printer.		
Ln		Log Number		
rS		Sets Display Resolution 0 & 1 = Resolution of 1 least significant digit 2-255 = Resolution setting of last digits		
InP	Input	Automatically returns the LCA15 to the input after scrolling Variable sequence is completed and updates permanent memory.		

Note: Invalid parameter values - Should an invalid figure be entered against any parameter, it will be rejected and the display will return to show the parameter.

<b>Chapter 1 Introduction to the LCA15</b> .....	<b>5</b>
Figure 1.1 Bagging .....	6
Figure 1.2 Drum Filling .....	6
Figure 1.3 Mixing Control .....	6
<b>Chapter 2 Installing the LCA15</b> .....	<b>7</b>
Environmental Requirements .....	8
Conditions .....	8
Terminal Connections .....	8
Figure 2.1 The LCA15 Field Connection Terminals.....	9
Figure 2.2 IP65-ABS Case (LAB) Dimensions & Mounting Points.....	9
Figure 2.3 DIN Rail Mounting (D2) Dimensions.....	9
Figure 2.4 LCB Dimensions - Side View .....	10
Figure 2.5 LCB Board .....	10
Figure 2.6 The 4 Wire Strain Gauge .....	10
Figure 2.7 The 6 Wire Strain Gauge .....	10
<b>Chapter 3 The LCA15 Controls &amp; Parameters</b> .....	<b>11</b>
Figure 3.1 Programmer Unit Panel Layout .....	11
Table 3.1 Control Panel Guide .....	11
The Configurable Parameters .....	12
Configurable Parameters .....	12
Table 3.2 .....	12
<b>Chapter 4 Strain Gauge Input to the LCA15</b> .....	<b>14</b>
The Strain Gauge Input.....	14
Hardware Configuration:.....	14
Auto Calibration.....	15
Display Averaging (dA) .....	15
Table 4.1 .....	16
Display Averaging with Peak Hold .....	16
Input Filtering .....	16
<b>Chapter 5 Analogue Outputs</b> .....	<b>17</b>
Output Scaling .....	17
Figure 5.1 Analogue Output .....	17
Method of Calculating OPL & OPH from any known output values.....	18
Calibration .....	18
Figure 5.2 Showing the Potentiometers for Gain & Offset Adjustment .....	18
<b>Chapter 6 Relay Output Module</b> .....	<b>19</b>
Module Functions.....	19
Set Points (SP) .....	19
In Flight Compensation.....	19
Hysteresis (HYS) .....	19
Output Action (OA) .....	20
Latching Outputs .....	20
Figure 6.1 LR1 Module.....	20
Installation of LR1 .....	20
<b>Chapter 7 The Communications Port</b> .....	<b>21</b>
Introduction .....	21
Serial Communication Protocol .....	21
Fast MANTRABUS Format - selected when CP is 128 .....	21
Operation.....	21
Updating.....	22
Communications Commands.....	22
Command 1 Request for all data: .....	23
Response To Command 1 from LCA15 .....	23
Command 2 Request Display Data .....	23
Response To Command 2 from LCA15 .....	23
Commands 3 To 18: Write data to LCA15 Parameter .....	24
Response to Command 3 to 22 .....	24
Command 19: EEPROM Enable / Disable .....	24

Command 20: Output Relay Reset .....	25
Command 21: Auto Tare .....	25
Command 22: Peak Hold Reset .....	25
ASCII Format - selected when CP is 129 .....	26
Instruction Set for ASCII Serial Communications .....	27
Table 7.1 .....	27
Modbus Protocol .....	28
LCA15 Printer Format .....	29
Figure 7.1 LC1 Current Loop .....	31
Figure 7.2 Connecting Multiple LCA15s .....	31
Figure 7.3 The LC3 Isolated RS232/485 - RS485 Mode Connections .....	32
Figure 7.4 Connecting Multiple Units on RS485 .....	32
Figure 7.5 RS232 Mode Connection to PC .....	32
Figure 7.6 RS232 Mode Connection to Printer .....	33
<b>Chapter 8 Trouble Shooting Guide .....</b>	<b>34</b>
<b>Chapter 9 LCA15 Specifications .....</b>	<b>35</b>
DC Analogue Outputs .....	35
Control / Alarm Relay Output .....	35
The Communications Port Data .....	35
Data Retention and Protection .....	36
Environmental .....	36
Physical .....	36
Power Supplies .....	36
LCA15 Order Codes .....	37
Instrument Setup Record Sheet .....	38
<b>W A R R A N T Y .....</b>	<b>38</b>

## *Chapter 1 Introduction to the LCA15*

The In Line Intelligent Strain Gauge Amplifier LCA15 is a compact microprocessor based unit specifically designed to control weighing applications.

Its flexibility of design allows for the connection of most Strain Gauges, pressure or strain gauges over a wide range of sensitivity.

Housed in a light grey, ABS case, it is sealed to IP65 standard to meet most environmental conditions.

The basic unit offers the following facilities:-

A simple auto calibration of the highest and lowest weights required, an easy auto tare setting and peak hold facility. A password facility gives protection to setup parameters.

DC analogue outputs of 4-20mA and 0-10V are standard with full scaling over any desired range and the ability to invert these outputs if required.

Gain sensitivity is selectable via DIL switches between 0.5 and 200mV/V.

Several 'plug in' options are available. An optional relay output module provides for 2 set points and hysteresis can be applied to both set points together with In Flight compensation. Relays can be inverted and latched. All these facilities being set digitally in real engineering terms from the plug in programmer unit or from an optional internal display module. Both relay and analogue outputs have a high level of isolation.

An Optional communications modules provide for 20mA noise immune current loop, RS232 or RS485 connections to a PC, PLC or main frame. This allows for the input variable to be viewed and any setup parameters changed.

Multiple 20mA LCA15s can be connected via an IF25 current loop to RS232 interface which, when included, allows for an expansion of up to 250 LCA15s.

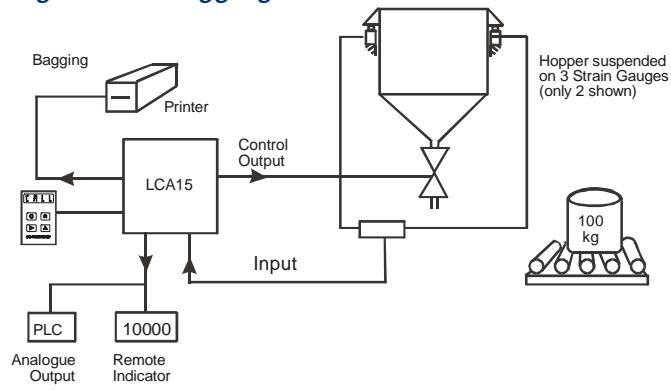
The RS232 port is available for Time/Data or data only printers to be used, logging all desired activities.

Baud speeds between 300 and 19200 are programmable.

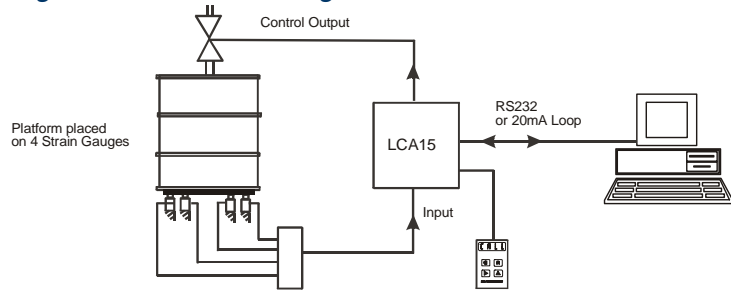
The power supply module is available for 220/240V AC and 110/120V AC or 24/48V DC.

Further options provide the LCA15 in an IP65 die cast case for harsh environments or a PCB only (Eurocard) version is available for customers enclosures. Two variants are available for rack mounting.

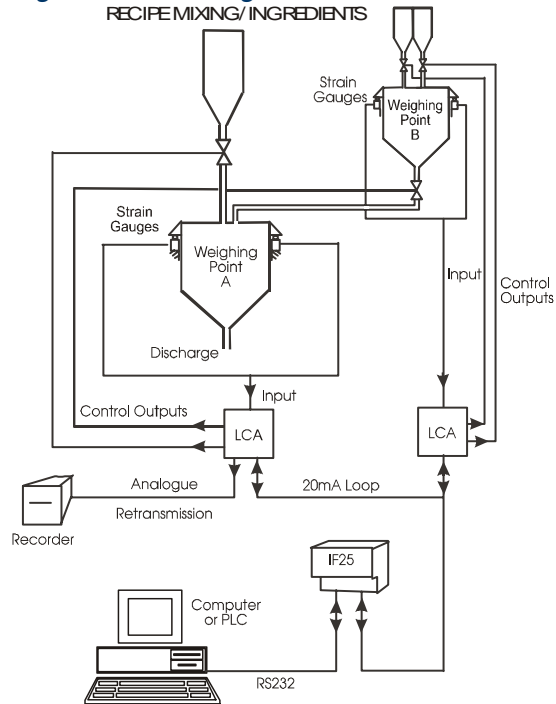
**Figure 1.1 Bagging**



**Figure 1.2 Drum Filling**



**Figure 1.3 Mixing Control**



## Chapter 2 Installing the LCA15

### Environmental Approvals

Emissions BS EN 55011:1998

Immunity BS EN 61000-4-2:1995 IEC 6100-4-2:1995  
BS EN 61000-4-3:2002  
BS EN 61000-4-4:2004  
BS EN 61000-4-11:2004

Output shall not exceed the sum of uncertainties when subjected to an electric field of 10V/m over the frequency range 80 to 600MHz

Safety/Low voltage Directive 73/23/EEC as amended by 93/68/EEC  
BS EN 61010-1:2001 IEC 61010-1:2001

LCA15 Complies with IEC 1010-1:1990 Part 1 for:-

- Rated for Basic Insulation
- Normal Condition
- Pollution Degree 2
- Permanently Connected
- Insulation Category III

In order to maintain compliance with the EMC Directive 89 / 336 / EEC the following installation recommendations should be followed.

**Inputs:** Use individually screened twisted multipair cable. (e.g. FE 585 - 646)  
The pairs should be :  
pins 1 & 6  
pins 2 & 5  
pins 3 & 4  
Terminate all screens at SCR. The screens should not be connected at the transducer end of the cables.

**Comm's Port:** Use individually screened twisted multipair cable. (e.g. FE 118-2117)  
the pairs should be:  
-Tx & +Tx  
-Rx & +Rx  
Terminate screens at SCR.  
The screens should not be connected at the host port.

**Analogue Output:** Use screened twisted pair cable. (e.g. RS 626-4761)  
  
Terminate screen at SCR.  
The screen should not be connected at the host port.

SCR should be connected to a good Earth. The Earth connection should have a cross-sectional area sufficient enough to ensure a low impedance, in order to attenuate RF interference.

Cable Information (For Reference only)

Country	Supplier	Part No	Description
UK	Farnell	118-2117	Individually shielded twisted multipair cable (7/0.25mm)- 2 pair Tinned copper drain. Individually shielded in polyester tape. Diameter: 4.1mm Capacitance/m: core to core 115 pF & core to shield 203 pF
UK	Farnell	585-646	Individually shielded twisted multipair cable (7/0.25mm)- 3 pair Tinned copper drain. Individually shielded in polyester tape. Diameter: 8.1mm Capacitance/m: core to core 98 pF & core to shield 180 pF
UK	RS	626-4761	Braided shielded twisted multipair cable (7/0.2mm)- 1 pair Miniature- twin -round Diameter: 5.2 mm Capacitance/m: core to core 230 pF & core to shield 215 pF

### Environmental Requirements

LCA15 units can operate in any industrial environment provided the following limits are not exceeded at the point of installation:

Operating Temperature: -10 °C to 50 °C  
 Humidity: 95 % non condensing  
 Storage Temperature: -20 °C to +70 °C

Two power supply options are available  
 Units can operate from the following:-

220/240V AC, 50/60Hz 10W LS1 110/240  
 110V AC, 50/60Hz 10W

9-32V dc, 10W LS3 (Running current 300 - 530mA Dependent upon  
 module configuration)  
 (start up current - 3Amps for 20mS)

### Conditions

	Power in Watts
I. LCA15F and LP1 with 1 x 350R Strain Gauge connected, and a 4-20mA analogue output providing 20mA into a short circuit	12 : 24V 2.24 2.88
II. With relay module fitted, add	0.58W 0.65W
III. With RS232 module fitted- no device connected, add	0.07W 0.09W
IV. For each additional 350R Strain Gauge, add	0.38W 0.48W

Note: Maximum number of Strain Gauges = 6 x 350R or equivalent

### Terminal Connections

Connection between the LCA15 unit and input/output signals, including power supplies, are made via 2.5mm field terminal blocks inside the unit.

Access to the terminals is made through glands in the bottom of the case.

(See Figure 2.1)

Figure 2.1 The LCA15 Field Connection Terminals

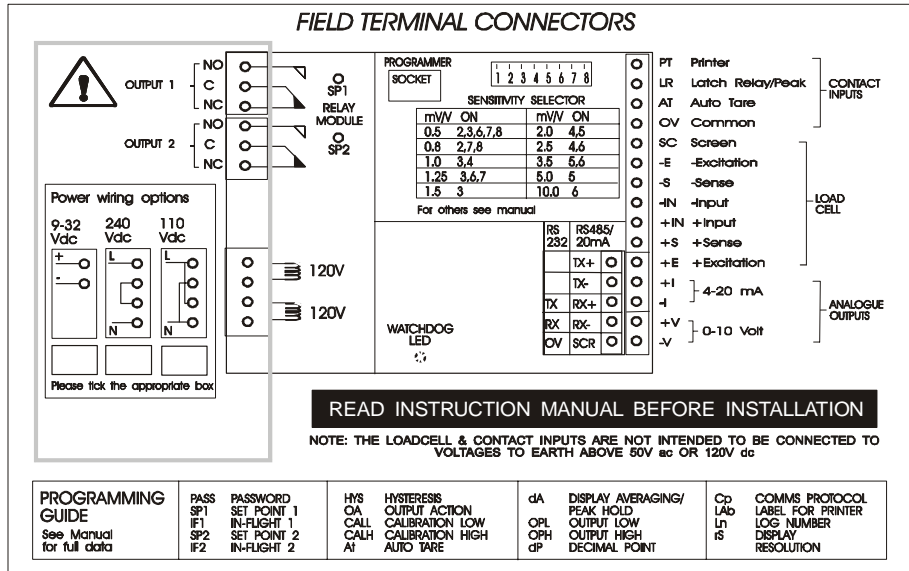


Figure 2.2 IP65-ABS Case (LAB) Dimensions & Mounting Points

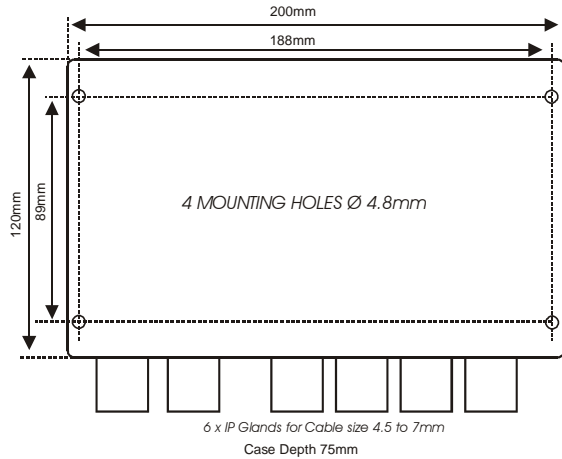
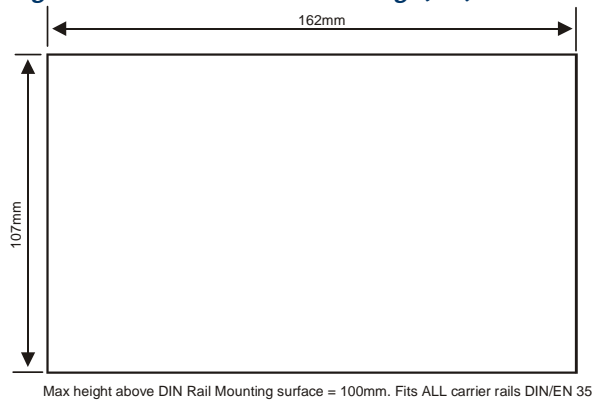
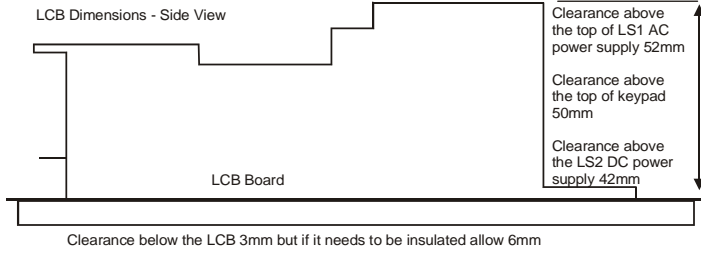


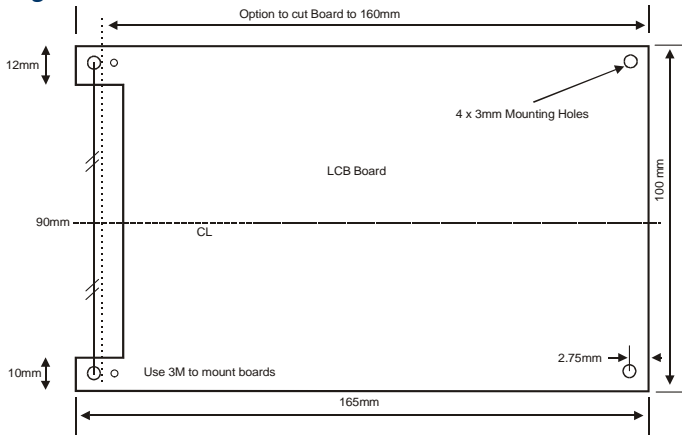
Figure 2.3 DIN Rail Mounting (D2) Dimensions



**Figure 2.4 LCB Dimensions - Side View**

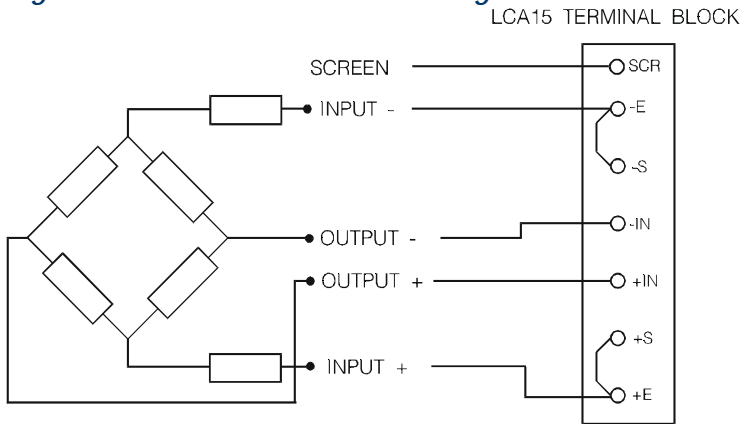


**Figure 2.5 LCB Board**

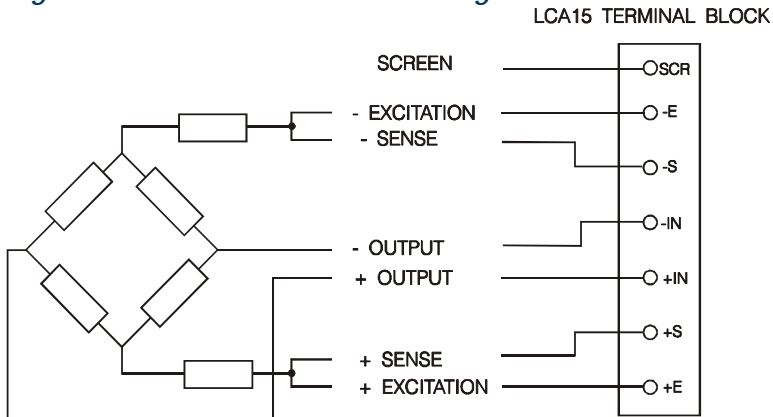


LCB with DIN Rail Mounting allow 165 x 105 mm

**Figure 2.6 The 4 Wire Strain Gauge**



**Figure 2.7 The 6 Wire Strain Gauge**



## Chapter 3 The LCA15 Controls & Parameters

The Programmer Unit - Is a small hand held unit together with a connection lead, which plugs into a 'FFC' type socket on the main assembly board. There is also an option for a permanent field programmer fitted internally.

All user controls, displays and indicators are mounted on the front panel which provides a 4.5 digit, LCD display and four flush mounted keys .

A flashing ---- symbol in the top left hand corner of the display indicates programming mode

Figure 3.1 Programmer Unit Panel Layout

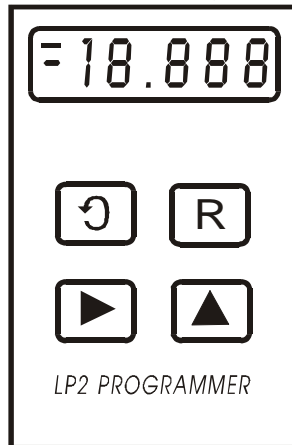


Table 3.1 Control Panel Guide

- |   |  |
|---|--|
| ⤿ | Used to scroll through and change the set up data by displaying mnemonics for each configurable parameter, followed by the appropriate data.<br>When in programming mode it should be noted that the first digit in the display may not be visible, but the program indicator --- will be flashing to indicate that the instrument is in programming mode, even though no digits can be seen to be flashing. |
| ▶ | Selects the display digit required. Selection value is indicated by a flashing digit and flashing program indicator  |
| ▲ | Increments each selected display digit 0-9.<br>Pressing the ▲ key under programming conditions will display the leading digit as either 1, -1, or a blank display for zero.  |
| R | Resets the display to the input variable and enters new data in the LCA15 memory. Returns the display to the current value after Hold.<br>If during the programming sequence, selection is not completed, the display will revert to the input variable after 2 minutes.   |

## The Configurable Parameters

A series of parameters or programmable functions are provided in the LCA15 to allow the user good flexibility for monitor and control applications.

These parameters are included as constants in the LCA15 database and are accessed and checked via the programmer keypad or the communications port.

Data which is entered by the user is retained by EEPROM for up to 10 years without back up power.

New data, when entered, overwrites previous entries when the **R** key is pressed unless the EEPROM has been disabled via the communications port.

### Password Protection

A 4 digit password number must be entered. The number is accessed when 'PASS' is displayed. At this point, it is necessary to enter either the factory set number (contact supplier) in digit positions 2-5, or the password number specifically ordered by the customer.

## Configurable Parameters

Table 3.2

Code	Value	Function
PASS	±19999	Security Password. Correct value required to proceed further.
SP1	±19999	Set Point 1 'desired' trip value of output 1
IF1	±19999	In-Flight compensation for SP1 Relay 1 operates at = SP1 - IF1
SP2	±19999	Set Point 2 'desired' trip value of output 2
IF2	±19999	In-Flight compensation for SP2 Relay 2 operates at = SP2 - IF2
HYS	0-19999	Hysteresis amount applied to SP1 and SP2
OA	0-31	Output Action. Relays energise or de-energise above SP level. Analogue output normal or inverted, and latching
CALL	±19999	Calibration Low. Display value for low calibration point(Must be less than CALH)
CALH	±19999	Calibration High.Display value for high calibration point Note: When CALH = 0, the LCA15 display scaling is -19999 to +19999
At	±19999	Auto Tare value
dA	0-7	Display Averaging 1 to 64 standard display updates
	8-15	Display Averaging 1 to 64 display updates for peak hold
OPL	±19999	Output Low (minimum) Display point for minimum analogue output
OPH	±19999	Output High (maximum) Display point for maximum analogue output
dP	Decimal Point	Code                      dP Position 0                            19999                      To set the required position of the decimal point on the display. 1                            1.9999 2                            19.999 3                            199.99 4                            1999.9 5                            19999.
Cp	0-129	Comms Protocol 0 to 127 = Printer, 128 = 'Fast' MANTRABUS, 129 = 'ASCII'
SdSt	0-254	Serial Device Station Number. This is the address code for each LCA15 when the communications port is used.
or		Selects the desired label for the printer.
LAB		Log Number
Ln		Sets Display Resolution
rS	0-255	0 & 1 = Resolution of 1 least significant digit 2-255 = Resolution setting of last digits

Automatically returns the LCA15 to the input after scrolling

InP      Input      sequence is completed and updates permanent memory.  
Variable

**Note:** Invalid parameter values - Should an invalid figure be entered against any parameter, it will be rejected and the display will return to show the parameter mnemonic.

## Chapter 4 Strain Gauge Input to the LCA15

### The Strain Gauge Input

The LCA15 offers a direct connection to most low level (foil) strain gauge sensors.

The following example is for calibration of a Strain Gauge.

A 10 volt excitation is provided and it is monitored to compensate for any variation due to supply drift, load regulation or voltage drop in the cable between the sensor and the LCA15.

The maximum supply current is 150mA which allows for the connection of 4 x 350 Ohm Strain Gauges.

Strain Gauge sensitivity is preset via DIL switches to 0.5, 0.8, 1.0, 1.25, 1.5, 2.0, 2.5, 3.5, 5, 10, 20, 50, 100 and 200 mV/V. Select the next value higher than the Strain Gauge output maximum.

SW1 mV/V	1	2	3	4	5	6	7	8
0.5	-	x	x	-	-	x	x	x
0.8	-	x	-	-	-	-	x	x
1.0	-	-	x	x	-	-	-	-
1.25	-	-	x	-	-	x	x	-
1.5	-	-	x	-	-	-	-	-
2.0	-	-	-	x	x	-	-	-
2.5	-	-	-	x	-	x	-	-
3.5	-	-	-	-	x	x	-	-
5.0	-	-	-	-	x	-	-	-
10.0	-	-	-	-	-	x	-	-
20.0	-	-	-	-	-	-	x	x
50.0	-	-	-	-	-	-	-	x
100.0	-	-	-	-	-	-	-	-
200.0	x	-	-	-	-	-	-	-

x = ON - = OFF

mV/V =  $\pm$ mV/V nominal full range gain within  $\pm$ 3%

### Hardware Configuration:

The LCA15 is supplied set to  $\pm$ 2.5mV/V maximum. To check if the Strain Gauge and application is within this range, apply the following formula:

$$\frac{\text{Maximum load (weight) x Strain Gauge output voltage}}{\text{Strain Gauge rated range}}$$

For example:

$$\frac{1.5 \text{ tonne} \times 2.5\text{mV/V}}{2 \text{ tonne}} = 1.875\text{mV/V}$$

From the resultant figure select the next highest mV/V setting from the table (see above).

Before any calibration can be set, it will be necessary to decide upon the calibration values and place the decimal point in the appropriate position. To do this, scroll through the parameters, entering the password as appropriate (as described in Chapter 3), until the decimal point parameter is reached (dP). Once the decimal point is set, the auto calibration parameters can be set in real engineering terms.

## Auto Calibration

Connect the Strain Gauge, switch on the LCA15. Connect the Programmer for (RL1) version. Allow a warm up period of 10 minutes before carrying out the procedure as follows;

- a) Press the **[G]** key until PASS appears.
- b) Enter the password using **[▶]** and **[▲]** keys, then press **[G]** key.
- c) Keep pressing the **[G]** key until CALL (Cal Low) appears.
- d) Press the **[▶]** key and check that the program light flashes.\*

*\*IMPORTANT NOTE: Always ensure that the programmer indicator flashes, even though the displayed value may not need to change.*

- e) Check that the displayed value agrees with the low calibration weight applied to the Strain Gauge (this may be zero).

If this is not correct, alter the display value by pressing the **[▶]** & **[▲]** keys.

Ensure that the Strain Gauge is free from disturbance and press the **[G]** key to capture and calibrate the CALL value.

- f) CALH (Cal High) now appears on the display.
- g) Press the **[▶]** key and check that the program light flashes.
- h) Apply the known higher value weight.

Check that the displayed value agrees with the high calibration weight applied to the Strain Gauge.

If this is not correct, alter the display value by pressing the **[▶]** & **[▲]** keys.

Ensure that the Strain Gauge is free from disturbance and press the **[R]** key. The display will now indicate the Strain Gauge auto calibrated high value.

Note 1: The Calibration value is not entered into the memory until either the **[G]** key or the **[R]** key is pressed.

Note 2: CALH must always be greater than CALL, in both weight and entered values.

Note 3: Pressing the **[R]** key at any time will return the display to normal operation.

Note 4: For best accuracy and resolution, the calibration weight should be approximately 75% of the Strain Gauge capacity.

Note 5: For range check before autocal, set CAL H to 0 and display will be that of the A/D counts. It is important that the A/D span between the CALL weight and CALH weight, is greater than the span of the values entered for CALL and CALH, otherwise the display resolution will not be 1digit.

Note 6: CALH can be set before CALL if required.

Note 7: CALH and CALL can be programmed individually with any time period between provided that the **[R]** reset key is pressed to store the value.

## Auto Tare

The auto tare facility allows for any unwanted weight or tare value to be compensated for in the weighing process.

Compensation is achieved by closing a volt free contact between AT & 0V on terminals.

It is possible to view the Auto Tare value by scrolling to the At mnemonic which will display the offset present in the auto tare mode.

If required Auto Tare can be adjusted to any desired value to give a zero or fixed offset. The unit may also be 'Tared' from the 'Reset' terminals - see dP mnemonics in Chapter 3

## Display Averaging (dA)

In certain applications, due to the rapid changes in the display, the least significant digits may not be readable. In these cases, the LCA15 readings may be averaged over a number of updates and can be set as follows:

**Table 4.1**

	Display update time	
0 = 1 reading (standard)	approx. 0.4s	-(average of (4) readings) at 100mS
1 = 2 readings	approx. 0.8s	
2 = 4 readings	approx. 1.6s	
3 = 8 readings	approx. 3.2s	
4 = 16 readings	approx. 6.4s	
5 = 32 readings	approx. 12.8s	
6 = 64 readings	approx. 25.6s	
7 = Fast update mode	approx. 0.1s	

### **Display Averaging with Peak Hold**

A Peak Hold function, which will display and hold the highest recorded value of the measured input, can be set through the Display Averaging setting by adding 8 to any of the above settings. Reset Peak Hold by operating a closing contact connected between 'LR/PT' terminal and '0' volts, on the field terminals.

Where an Auto Tare value and Peak Hold are both operative, it is important to be aware that an Auto Tare function, although activated in the normal way, will zero the input but not the display, which will retain the peak value.

Peak hold will hold the analogue output relay and comms value.

### **Input Filtering**

Response for 15mV rms at 50Hz signal applied on a 25mV Full Range Input will give 1 part in 1,500 display digit noise.

## Chapter 5 Analogue Outputs

Two analogue outputs are available offering a DC current range and a DC voltage range.

They are fully scalable, optically isolated and generated from the displayed input value. The 4 to 20mA output is pre calibrated to an accuracy of within 0.15% of the range. The 0-10V output is accurate to within 2% of the 4 to 20mA output.

OUTPUT	RANGE
DC voltage	0V to 10V
DC current	4 to 20mA

Notes:

1. Maximum current load on voltage modules is 2mA
2. Maximum drive voltage available in current modules is 20V

### Output Scaling

Output scaling factors are set by the user and determine the display range over which the analogue module operates.

(OPL) Output Low - This sets the displayed value at the module's minimum output.

(OPH) Output High - This sets the displayed value at maximum output. If the display is outside the range defined by OPL and OPH, the analogue output will remain constant at its minimum or maximum output value.

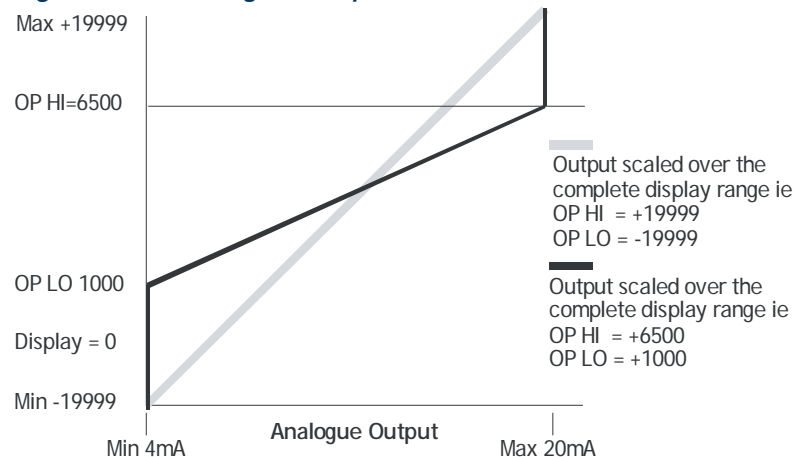
Inversion of the analogue output can be set by the output action mnemonic OA (See Relay Output Module Chapter 6).

Example: Assume a 4-20mA output module is required to provide an output of 4mA for 1000Kg and 20mA for 6500Kg.

Set OPL to 1000 and OPH to 6500

It will be necessary to determine OPL and OPH by graphical or mathematical means if the known display values do not coincide with the minimum and/or maximum analogue output.

**Figure 5.1 Analogue Output**



## Method of Calculating OPL & OPH from any known output values

$$\text{OPL} = \frac{\text{Low Display} - (\text{Display span}) (\text{Low output} - \text{Min output})}{(\text{High output} - \text{Low output})}$$

$$\text{OPH} = \frac{\text{High Display} + (\text{Display Span}) (\text{Max output} - \text{High output})}{(\text{High output} - \text{Low output})}$$

Low output = Known low output

High output = Known high output

Min output = Lowest measurable value of output module

Max output = Highest measurable value of output module

Display span = Highest required display value minus lowest required display value.

Example:

Using a 4.20mA output module where it is required to produce 6mA at a display value of 400 and 18mA at a display value of 1100.

$$\text{OPL} = 400 - \frac{(700) (6 - 4)}{(18 - 6)} = 400 - \frac{1400}{12}$$

$$\text{OPL} = 400 - 116.66$$

$$\text{OPL} = 283.34$$

$$\text{OPH} = 1100 + \frac{700) (20 - 18)}{(18 - 6)} = 1100 + \frac{700 \times 2}{12}$$

$$\text{OPH} = 1100 + 116.66$$

$$\text{OPH} = 1216.66$$

Note 1: OPH must be greater than OPL

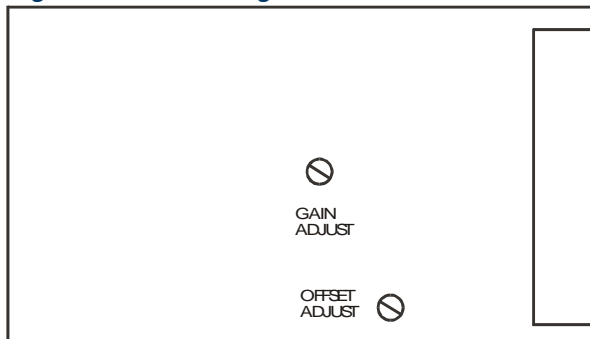
Note 2: If OPL or OPH are greater than  $\pm 19999$  then divide both OPL and OPH by 10, this will give less resolution. Decimal point can be placed anywhere to suit reading.

## Calibration

Re calibration can be made by adjusting the gain and offset potentiometers, or by adjusting the values of OPL and OPH.

An offset can be achieved by increasing the values of both OPL and OPH, and the gain by increasing the range between OPL and OPH.

Figure 5.2 Showing the Potentiometers for Gain & Offset Adjustment



## Chapter 6 Relay Output Module

### General Description

The Relay output module provides output control signals which can be used for switching functions such as ON/OFF control and alarm indications. The relays are activated by the values programmed for the Set Points. The output configuration will be for open or closed relay contacts and latching.

Output	Function
2 Relays	SPCO on SP1 and SP2

The connections for which are shown in Chapter 2

### Module Functions

The LCA15 can be programmed so that the relay output module reacts to all or any of the following functions:

- Set points
- In Flight compensation
- Hysteresis
- Relay inversion
- Latching

### Set Points (SP)

Set points are used to produce output signals at any required value so that the operation of the monitored process can be maintained to preset levels. Any excursion beyond set points will activate the relay or relays, to provide alarm or initiate control as required.

Two set points (SP1) and (SP2) can be programmed to suit different applications. The actions of either or both set points can inverted if required.

For normal operation the set point output is active until the input reaches the set point level. In this condition when the input value is less than the set point, the SP indicator is on and the output relay is energised producing a closed circuit on a normally open contact. When the set point value is reached, the SP indicator is off and the relay is de-energised producing an open circuit output.

For an inverted operation the reverse conditions apply.

Normal and inverted action is determined by the direction of the input value as it changes.

For example: In alarm applications.

A High-High operation allows for a rising input value to operate on two set points to define an acceptable quantity, weight or band of operation.

A Low-Low operation operates on a falling value.

A High-Low operation will operate on a rising or falling value, setting a 'band' by one set point operating normally and the other being an inverted action.

### In Flight Compensation

The setting of an In Flight value causes the set points to automatically adjust to control the flow of the material being weighed.

For example, if SP1 is used to control a flow, a certain amount will be 'In Flight' between the supply point and receiving point causing a positive error when the required weight is reached. The In Flight compensation value is adjusted by the user to 'reduce' SP1 to prematurely stop the flow, allowing the In Flight amount to make up the required total set by SP1. A similar situation exists for SP2.

### Hysteresis (HYS)

Once a Hysteresis value has been set, it will be applied to both set points entered. It is effective for both normal and inverted action.

When Hysteresis is applied to set points with normal output action, the input is allowed to rise to the set point value and the output is then turned off. The output is held off until the input value has dropped to the set point minus the Hysteresis value.

For inverted action the input drops to the set point and the output goes off and comes on again when the input rises to the set point plus the Hysteresis value.

### Output Action (OA)

The Output Action facility allows the user to determine whether set points produce normal or inverted and latched or unlatched output operation. The Output Action (OA) is entered by a code to suit the requirements of the user. Thirty two Output Action options are available.

The value of the OA to be entered in the algebraic sum of the following components:-

SP1 Inverted	= 1
SP2 Inverted	= 2
AN-OP Inverted	= 4
SP1 Latched	= 8
SP2 Latched	= 16

Example 1: If SP1 requires to be latched and inverted and the analogue output is normal, enter  $8 + 1 = 9$

Example 2: To invert the analogue output and latch SP2, enter  $4 + 16 = 20$

### Latching Outputs

The latching facility allows the relay module output to be held until reset externally. Latching is applied to the off status of the relay SP1 or SP2.

Figure 6.1 LR1 Module

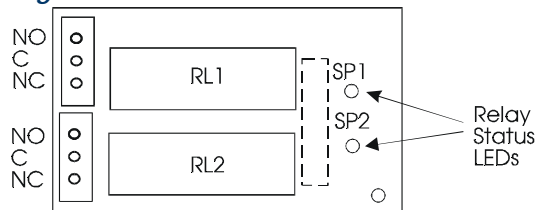
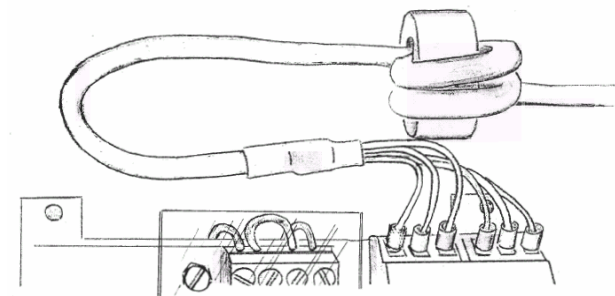


Figure 6.2 Installation of LR1



To meet the Specified EMC Fast transient requirements it is important that the ferrite ring supplied is fitted as per the following instructions.

Illustration showing ferrite ring FEC 323-4940 fitted to the LR1 relay wiring.

Two turns of the wiring are passed through the ring positioned 12cm from the LR1 end of the cable to improve immunity to electrical fast transients and bursts.

## Chapter 7 The Communications Port

### Introduction

The LCA15 communications port provides for a 2 way data link. An intelligent host e.g. Personal Computer, Main Frame or PLC is able to acquire the LCA15's displayed value and read or modify the user configurable parameters, using any of the following:-

- a) RS232 - for a one to one communication (as in the case of a printer, PC or PLC).
- b) RS485 - for the connection of up to 25, LCA units on a single RS485 line.
- c) 20mA Current Loop - for up to 250, LCA units on a single RS232 line, via the IF25 interface. With high noise immunity and isolation over distances up to 1Km.
- d) Baud Rates 300, 600, 1200, 4800, 9600
- e) Isolation  $\pm$  130V RMS or DC max to analogue input or any other port

4 communication formats, FAST MANTRABUS, ASCII, MODBUS RTU and PRINTER, are selected from the mnemonic CP via the keypad, of the programmer.

Integrity is ensured by pre-programmed default parameters should a loss of communications with the host occur.

### Serial Communication Protocol

#### General

Incoming data is continually monitored by the LCA15 on its serial input line.

Each byte of data is formatted as an eight bit word without parity, preceded by one start bit and followed by one stop bit.

Transmission and reception of data up to 19.2K Baud is possible, the actual rate being selected by an eight-position slide switch on the communications module (of which only 7 positions are used). The Baud rate depends upon the communications, hardware specification, distance and cable type.

- Position 1 = 300
- Position 2 = 600
- Position 3 = 1200
- Position 4 = 2400
- Position 5 = 4800
- Position 6 = 9600
- Position 7 = 19200. (FAST MANTRABUS ONLY)

#### Fast MANTRABUS Format - selected when CP is 128

To signify commencement of a new 'block' of data, the HEX number FFH is used as a 'frame' character, followed by the station number of the unit under interrogation. This is entered via the LCA15 keypad under mnemonic SDSt and ranges from 0-254).

The LCA15 acts upon incoming data only if its own station number immediately follows the FFH character.

New data must be received as a string of four nibbles (bits 7-4 set to zero) which are assembled into two bytes and written into the variables store within the LCA15. The most significant nibble must be received first and the last nibble must have the most significant bit (bit 7) set to indicate the end of data. This is followed by the checksum. The data transmitted from the LCA15 is always sent as complete bytes. The station number precedes the data and the checksum follows the data. The data format used is signed 15 Bit. The most significant Bit of the most significant Byte is set for negative numbers.

#### Operation

There are two modes of operation, namely data requests by the host controller and data changes. Data requests from the LCA15 consist of either a complete dump of the data variables stores in RAM or the display reading.

Data changes consist of writing new data to LCA15 variables, thus changing parameters such as Set Points, in flights etc.

An acknowledgement message is returned to the LCA15 to indicate that the new data has been acted upon.

### *Updating*

The required mode or variable to be updated is determined by the station number followed by the command byte. An EXOR checksum consisting of the station number command byte and any following data must be appended to the received data. It is most important that the byte proceeding the checksum must have its most significant bit set to signify the end of data.

The LCA15 works out its own checksum and, if it disagrees with the received one, a not acknowledge (NAK) message is returned.

### *Communications Commands*

The following is a list of commands available for reading to or writing from the LCA15.

COMMAND No.

Dec	Hex	Description
1	1	REQUEST ALL DATA INCLUDES WEIGHT INPUT
2	2	REQUEST DISPLAY DATA
3	3	UPDATE SET POINT 1 (SP1)
4	4	UPDATE IN-FLIGHT 1 (IF1)
5	5	UPDATE SET POINT 2 (SP2)
6	6	UPDATE IN-FLIGHT 2 (IF2)
7	7	UPDATE HYSTERESIS (HYS)
8	8	UPDATE OUTPUT ACTION (OA)
9	9	RESERVED
10	A	RESERVED
11	B	RESERVED
12	C	RESERVED
13	D	UPDATE AUTO TARE (At)
14	E	UPDATE DISPLAY AVERAGES AND HOLD FUNCTION (dA)
15	F	UPDATE OUTPUT LOW (OPL)
16	10	UPDATE OUTPUT HIGH (OPH)
17	11	UPDATE DECIMAL POINT AND RESET FUNCTION (DP)
18	12	CAN NOT BE WRITTEN TO, AND LCA WILL RETURN A NAK (SDSt/CP) EEPROM
19	13	ENABLE/DISABLE
20	14	OUTPUT RELAY RESET
21	15	AUTO TARE
22	16	PEAK HOLD RESET

### **Command 1** Request for all data:

DATA TRANSMITTED TO LCA15 FOR COMMAND 1

0FFH, Station Number, 081H, Chksum

Where Chksum = Station number EXOR with 081H.

Example: To obtain a complete dump of the variables in the LCA15 whose Station number is 47 send the following Data:-

0FFH, 02FH, 081H, 0AEH

|  
Note MS Bit Set

### **Response To Command 1 from LCA15**

BYTE

1	Station number
2,3	DISPLAY
4,5	SET POINT 1
6,7	IN FLIGHT 1
8,9	SET POINT 2
10,11	IN FLIGHT 2
12,13	HYSTERESIS
14,15	OUTPUT ACTION
16,17	A/D COUNTS FOR LOW CALIBRATION POINT
18,19	A/D COUNTS FOR HIGH CALIBRATION POINT
20,21	DISPLAY LOW CALIBRATION VALUE
22,23	ISPLAY HIGH CALIBRATION VALUE
24,25	AUTO TARE
26,27	DISPLAY AVERAGING
28,29	OUTPUT LOW
30,31	OUTPUT HIGH
32,33	DECIMAL POINT POSITION
34,35	STATION NUMBER
36	EEPROM ENABLE/DISABLE FLAG
37	RELAY STATUS
38	EXOR CHECKSUM OF THE ABOVE DATA

NOTE: Most significant byte proceeds least significant byte for data sent by LCA15.

### **Command 2 Request Display Data**

DATA transmitted to LCA15 for Command 2.

0FFH, Station number, 082H, Chksum

Where Chksum = Station number EXOR with 082H

Example: To obtain the display reading of an LCA15 whose station number is 47 send the following Data:

0FFH, 02FH, 082H, 0ADH

|  
Note MS Bit Set

### **Response To Command 2 from LCA15**

BYTE

1. Station No.
2. Display reading M.S. Byte.
3. Display reading L.S. Byte.
4. EXOR checksum of above data and Station No.

If, when using commands 1 or 2, an error is detected by the LCA15 then the Not Acknowledgement string is transmitted by the LCA15.

## Commands 3 To 18: Write data to LCA15 Parameter

Commands 3 to 18 all have the same format.

Format for data transmitted to LCA15 for Commands 3 to 18:-

OFFH, Station No, Command No, MSN, NMSN, NLSN, LSN, CHKSUM

Where MSN = Most significant nibble of data

NMSN = Next most significant nibble of data

NLSN = Next least significant nibble of data

LSN = Least significant nibble of data with MSBIT set

CHKSUM = The following EXOR'd with each other, Station number, command number, MSN, NMSN, NLSN, LSN with MSBIT set

Example: To change SP1 to 200.0 on an LCA15 whose station number is 47. The following data is sent.

Please note the following points apply:-

1. The decimal point is ignored i.e. 200.0 equals 2000 digits
2. The data is sent in Hex nibbles so 2000 = 00H, 07H, 0DH, 00H  
OFFH, 02FH, 03H, 00H, 07H, 0DH, 80H, 0A6H

|  
Note MSBIT set

## Response to Command 3 to 22

If the data has been accepted by the LCA15 then the following acknowledgement string is transmitted by the LCA15.

Station number, 06H (ACK)

If there are any errors with the data received by the LCA15 then the following Not Acknowledgement (NAK) string is transmitted by the LCA15:-

Station number, 015H (NAK)

## Command 19: EEPROM Enable / Disable

The EEPROM disable facility can be used for any of the following:  
cycles to EEPROM to limit degradation.

- I. To limit the number of write cycles to EEPROM reducing degradation.
- II. Change data in the LCA15 RAM only, allowing EEPROM to hold power up values.
- III. Leave base constants in the EEPROM for later update to RAM which allows manipulation of the data before writing to the RAM.

Writing new data from the RAM to the EEPROM.

EEPROM disable is achieved by writing 0100H to the LCA15 via command 19. In this state all writing to, or reading from the EEPROM is inhibited.

The EEPROM can be re-enabled in two ways:

By writing 0200H via command 19.

This writes the current contents of the variables store in the LCA15 into the EEPROM.

By writing 0400H via command 19.

This updates the variables store from the current contents of the EEPROM.

## Examples

To disable the EEPROM on an LCA15 whose Station number is set to 47

OFFH 02FH 013H 00H 01H 00H 080H 0BDH

To re-enable the EEPROM and update the RAM with the old EEPROM constants:

OFFH 02FH 013H 00H 04H 00H 080H 0B8H

To re-enable the EEPROM and update it with the new RAM data:

OFFH 02FH 013H 00H 02H 00H 080H 0BEH

For response see 'Response to Command 3 to 22'.

### ***Command 20: Output Relay Reset***

DATA transmitted to LCA15 for Command 20

OFFH, Station number, 094H, CHKSUM

Where CHKSUM = Station Number EXOR with 094H

Example: To output a relay reset to an LCA15 whose Station Number is set to 47

OFFH, 02FH, 094H, 0BBH

    |  
    Note MS BIT SET

For response by LCA15 see 'Response to Commands 3 to 22'

### ***Command 21: Auto Tare***

DATA transmitted to LCA15 for Command 21

OFFH, Station number, 095H, CHKSUM

Where CHKSUM = Station Number EXOR with 095H

Example: To output an Auto Tare command to an LCA15 whose Station Number is set to 47

OFFH, 02FH, 095H, 0BAH

    |  
    Note MS BIT SET

For response by LCA15 see 'Response to Commands 3 to 22'

### ***Command 22: Peak Hold Reset***

DATA transmitted to LCA15 for Command 22

OFFH, Station number, 096H, CHKSUM

Where CHKSUM = Station Number EXOR with 096H

Example: To output a Peak Hold reset to an LCA15 whose Station Number is set to 47

OFFH, 02FH, 096H, 0B9H

    |  
    Note MS BIT SET

For response by LCA15 see 'Response to Commands 3 to 22'

**Example of a Basic Code to Communicate with Fast Format**

open the serial port with no handshaking

```
OPEN"COM2:4800,N,8,1,RS,DS,BIN" FOR RANDOM AS#1
```

request display from device 1

Frame FF	Station No 1	Command 2 And add 80 hex to this byte as it is the last before as the checksum	Checksum of all bytes except frame
----------	-----------------	--	---------------------------------------

```
talk$=CHR$(&HFF)+CHR$(&H1)+CHR$(&H82)+CHR$(&H1 XOR&H82)
```

*print the string to the port*

```
PRINT#1,talk$;
```

*(must add semicolon after string to stop transmitting a carriage return)*

*wait for a while (this depends on how many bytes you are expecting and the baud rate!)*

*input all the bytes in the serial buffer*

```
input.from.lca$=INPUT$(LOC(1),#1)
```

### **ASCII Format - selected when CP is 129**

The serial data to and from the LCA15 is formatted as eight bit words with no parity preceded by one start bit and followed by one stop bit. The baud rate (up to 9.6k Baud) is selected on the COMMS module. All communications are carried out using the standard ASCII character set. Incoming line feeds and spaces are ignored; upper and lower case letters are permitted. The incoming data is continually monitored for Carriage Return characters (Chr\$13D). If one is received the next three characters (000 - 999) are compared with the LCA15 station number (SDST) previously entered via the keypad. N.B. leading zeros must be included. If no match is found the data that follows is ignored.

The next characters received (up to 4 max) are decoded as the 'label', ie. which variable in the LCA15 is to be acted upon. If the label is received incorrectly and cannot be decoded the LCA15 will return a '?' followed by a C.R. character. If the received label is followed by a C.R. the LCA15 will return the current value of the variable in question. (Because there is no hardware handshaking, all transmission from the LCA15 is performed one character at a time upon receiving a Null character (Chr\$0) prompt from the Host system. Thus for every character transmitted a prompt character is required. ) The output from the LCA15 is an ASCII string of sixteen characters the last one being C.R.

The first four characters are the Station No. (with leading zeros if necessary) followed by a space. The label then follows with spaces added if required to make a total of four characters. The next seven characters is the numerical value of the required variable with polarity, spaces, d.p. and leading zeros added as required. If the received label is followed by an '=' character the LCA15 accepts the following numerical data (which must be terminated by a C.R.) and updates the variable in question and returns a C.R. character to the host when prompted. Data input is reasonably flexible. If all five digits are entered, no decimal point need be included. If less than five digits are entered with no decimal point then the last digit is assumed to be the units.

Under normal circumstances the EEPROM in the LCA15 continually refreshes the working RAM. However, it can be disabled via the serial input, by sending the instruction 'DROM = 256' after the Station No. In this condition all read/write operations to or from the EEPROM are inhibited. There are two instructions which will re-enable the EEPROM:

- 1) 'ERRD' - this performs a read from the EEPROM and updates the working RAM with the contents of the EEPROM.
- 2) 'ERWR' - this instruction writes the new RAM values into the EEPROM.

In both cases the EEPROM continues to refresh the RAM.

### *Instruction Set for ASCII Serial Communications*

Request for data:

DATA sent to LCA15			Data returned from LCA15		
CR xxx	DISP	CR	xxx 'SPACE'	DISP	YYYYYY CR
Station No.	label		Station No.	label	numerical value
CR xxx	DOSP	CR	xxx 'SPACE'	DOSP	'SPACE' ? CR
Station No.	incorrect label		Station No.	incorrect label	

DATA sent to LCA15		Data returned from LCA15	
CR xxx	SP1 = 100.0		CR
Station No.,	label	numerical value	
CR xxx	SP3 = 100.0		?CR
Station No.,	incorrect label,	numerical value.	

**Table 7.1**

LABELS	DESCRIPTION
DISP	REQUEST DISPLAY READING
SP1	SET POINT 1 (SP1)
IF1	IN-FLIGHT 1 (IF1)
SP2	SET POINT 2 (SP2)
IF2	IN-FLIGHT 2 (IF2)
HYS	HYSTERESIS (HYS)
OA	OUTPUT ACTION (OA)
At	AUTO TARE(At)
DA	DISPLAY AVERAGES (dA)
OPL	OUTPUT LOW (OPL)
OPH	OUTPUT HIGH (OPH)
DP	DECIMAL POINT (dP)
SDST	CAN NOT BE WRITTEN TO (SDST/CP)
DROM	DISABLE EEPROM (DROM = 256)
ERRD	ENABLE EEPROM AND READ FROM IT
ERWR	ENABLE EEPROM AND WRITE TO IT
RLYS	OUTPUT RELAY STATUS ( 0 = BOTH OFF, 1 = RELAY 1 ON, 2 = RELAY 2 ON, 3 = BOTH RELAYS ON)
RES	OUTPUT RELAY RESET
TARE	AUTO TARE
PKR	PEAK HOLD RESET

## Modbus Protocol

This Modbus protocol has been implemented in accordance with Modicon Modbus Protocol Reference Guide P1 - MBUS - 300 Rev C. With the following conditions applying.

The following conditions apply

Baud Rate must be set for 9600

The format is Modbus RTU

UART's shall be set for 8 bit word, 1 start, 1 stop & no parity

Data is considered to be half duplex using 2 or 4 wire medium.

### To Select MODBUS Protocol Set CP = 130

Modbus states a new framing character is assumed after the time period to receive 3.5 characters (3.65mS) has elapsed. As a dedicated timer is not available for this function this time value has been increased to 25mS. This means the master must not transmit a new message until 25mS after the previous message last byte has been sent

The instrument only uses 3 commands. Read holding register , Preset single register & Preset multiple registers.

Read holding register & Preset multiple registers is limited to reading a **single** register.

Data is sent & returned as signed 15 bit ie 1000 = 03E8 & -1000 = 83E8.

Broad cast commands are not supported.

### Exception Responses

The following exception codes will be supported only,

01 Illegal function

02 Illegal data address

03 Illegal value

### Register Allocation

Register No.	Mnemonic
1	Display (net)
2	SP1
3	IF1
4	SP2
5	IF2
6	HYS
7	OA
8	ADCALL
9	ADCALH
10	CALL
11	CALH
12	AT
13	DA
14	OPL
15	OPH
16	DP
17	CP
18	SDST
19	RS
20	STATUS
100	AutoTare
101	Relay Reset
102	Disable EEROM
103	Enable RAM from EEROM
104	Enable EEROM from RAM

#### Example of reading a holding register.

Following example is for reading "Display (Net)" from station 1

Data sent = 01, 03, 00, 01, 00, 01, D5, CA (See MODBUS manual for reference)

Data returned = 01, 03, 02, MSB, LSB, CRC\_HI, CRC\_LO

#### Example of writing a holding register (Command 06).

Following example is for writing "IF1" = 1200 digits to station 1

Data sent = 01, 06, 00, 03, 04, B0, 7A, BE (See MODBUS manual for reference)

Data returned = 01, 06, 00, 03, 04, B0, 7A, BE

#### Example of writing a holding register (Command 16)..

Following example is for writing "IF1" = 1200 digits to station 1

Data sent = 01, 10, 00, 03, 00, 01, 02, 04, B0, CRCHi, CRCLo (See MODBUS manual for reference)

Data returned = 01, 10, 00, 03, 00, 01, B0, CRCHi, CRCLo

*Note only 1 register can be written to using command 16*

#### Action Commands

These are registers above 99. They are executed by writing to a holding register, the data sent is ignored. (See table.)

### **LCA15 Printer Format**

(CP must be set between 0 - 127)

Printer selection enables the LCA15 to print its current display value to a printer via its communications port. This display value can either be assigned a date and time stamp and/or a log number depending on the user set options entered under mnemonic 'CP'. The log number can be reset or preset using the mnemonic 'Ln'. This value is not saved on power fail. A label can be suffixed to the printed display value using the mnemonic 'Lab'. A large range of labels are available to the user.

The time and date are set in the TDP printer itself using its own menu. The printer allows the entry of an additional custom text message.

Three connections are required between the LCA15 communications port and the printer with a maximum cable length of 100 metres. (See Chapter 8 for Details)

*NOTE: The printer is not isolated from the Strain Gauge input. When using RS232 module the printer is not isolated from the input.*

#### Additional Mnemonics for the Printer Operation:

When the printer option is fitted further mnemonics are included in the normal range. After the dP mnemonic are the following:-

- CP At this mnemonic the printer type and print format number is selected. This number being appropriate to the type of printer used. Details are advised with each type of printer selected.  
Present types available are:- For the ITT IPP-144-40E printer the following numbers apply
- 0 Prints a sequential log number with the current display and unit of measure  
e.g. 00014 0011.3 tonne
  - 1 Prints date and time with a sequential log number, current display and unit of measure  
e.g. 00015 0001.7 tonne
  - 2 **13.07.99 12:05:06**

Prints a sequential log number, current display, unit of measure with customer text message No 1

3 e.g. MANTRACOURT ELECTRONICS LCA15 PRINTER  
00012 000.2 tonne

Prints date and time with a sequential log number, current display, unit of measure and a customer text message No.1

8,9 e.g. MANTRACOURT ELECTRONICS LCA15 PRINTER  
00013 0023.6 tonne  
13.07.99 12:03:04

4-7 Digitec 6700 series

8,9 Amplicon AP24 and AP40  
Eltron LP2142 - (The label file must be called 'MEL' and the label must contain a LOG NUMBER, THE DISPLAY VARIABLE & a LABEL (not zero).

12 ASCII string on print command

127 Continuous ASCII stream of the display data, transmitted on every display update

*Note:1 9 gives an inverted print out*

*Note: 2 it is anticipated that further types of printer will be added, and additional numbers will be allocated as appropriate*

LAb Label Number

A number can be selected for the appropriate unit of measure. See table below:

Note: 0 = NO LABEL

0	BLANK			
1	Deg R	18 m	35 ton	52 RPM1000
2	Deg C	19 in	36 %Dev	53 Hz
3	Deg F	20 ft	37 W	54 kHz
4	Kelvin	21 degrees	38 kW	55 V DC
5	lb/in 2	22 L/s	39 MW	56 mV DC
6	bar	23 L/min	40 pH	57 A DC
7	mbar	24 L/h	41 ppm	58 mA DC
8	kPa	25 gals/s	42 uS	59 V AC
9	atm	26 gal/min	43 Ohms	60 mV AC
10	mmHg	27 gal/h	44 m/s	61 A AC
11	inHg	28 %RH	45 ft/min	62 N
12	inH2O	29 gram	46 RPM	63 spare
13	cmHg	30 kg	47 RPMx10	64 spare
14	mm	31 lb	48 RPMx100	65 spare
15	Wh	32 kWh	49 cos @	66 spare
16	Db	33 mile/h	50 km/h	67 knots
17	tonne	34 %	51 ms	68 s

Ln Log Number

A range of numbers 0 to 19,999 is available. Any sequential number logging activity can be preset as desired, between these numbers. The number will reset to zero after 19,999. The log number is not saved on power fail and resets to zero on power up.

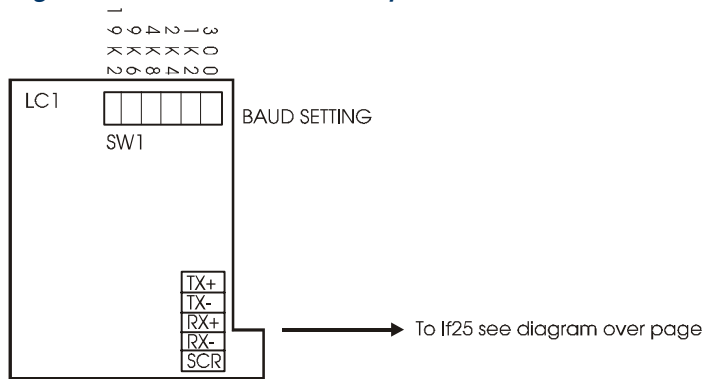
Provision is made in the LCA15 for communications via one of TWO module options:

LC1 The 20mA current loop module, for connection to an IF25 interface.

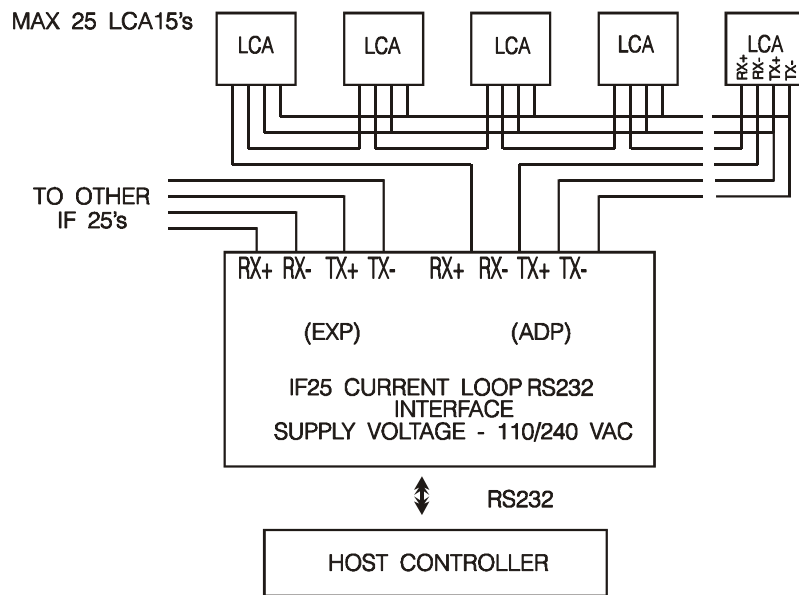
LC3 An RS232/485 isolated module, for connection to a PC or PLC, in a single or multiple function

Connections for these options are shown below:-

**Figure 7.1 LC1 Current Loop**



**Figure 7.2 Connecting Multiple LCA15s**



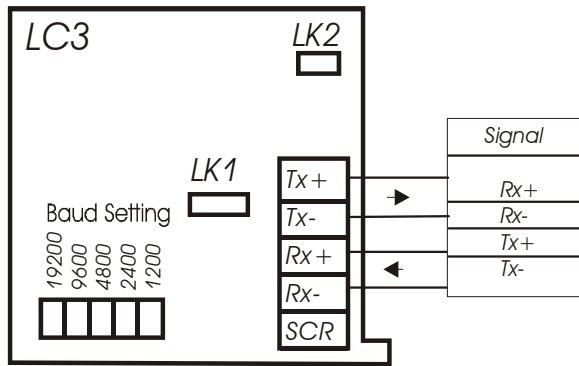
Connecting Multiple LCA15s to the IF25 Interface

Notes

- 1) Maximum loop voltage is 50V dc.
- 2) Loop is isolated from host and LCA15s. Loop should be earthed via Rx - on IF25/254
- 3) IF25 used for up to 25LCA15s.
- 4) At 19,200 Baud, max. cable length is 100m metres, using cable type BICC H8085.

LC3 Isolated RS232/485

Figure 7.3 The LC3 Isolated RS232/485 - RS485 Mode Connections



The SCR must not be used for RS232 connections.

For RS485 the SCR connection on the LC3's can be daisy chained together and connected to a screen or 0v if available from the 'masters' RS485 comms port.

When multi-dropping in RS485 mode - The last device only should be fitted with LK2, which acts as a 120R terminating resistor.

Figure 7.4 Connecting Multiple Units on RS485

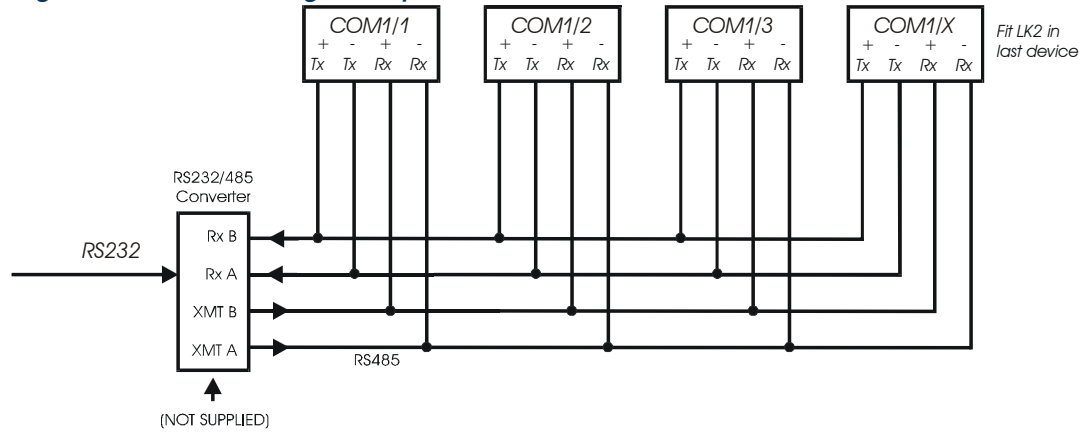
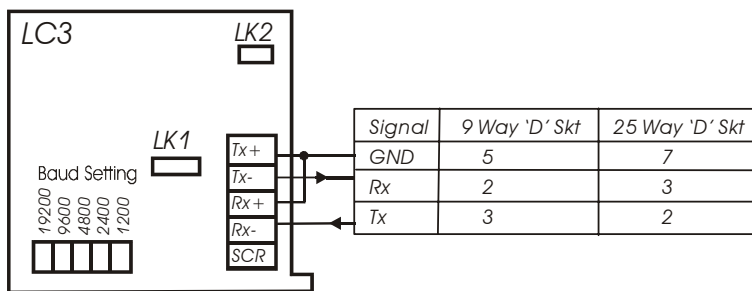


Figure 7.5 RS232 Mode Connection to PC

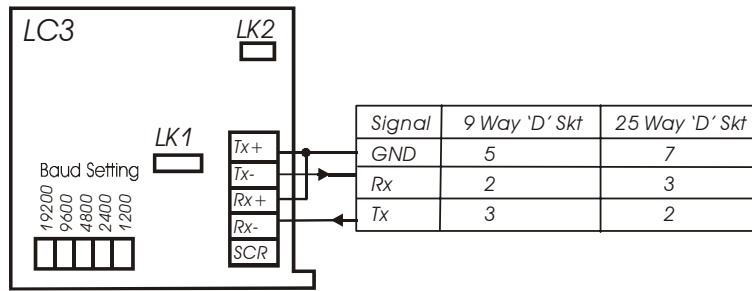
Note: LK1 Must be made for RS232 operation



### Figure 7.6 RS232 Mode Connection to Printer

Note 1: LK1 Must be made for RS232 operation

Note 2: If no RTS is available from the printer, fit LK2



**NOTE :**

When using an RS232 to RS485 converter which has a non-biased receiver, the following actions are recommended:-

To bias the device:

- 1) Terminate the receiver with 140R in place of the usual 120R
- 2) Fit a 1.5K from the receive negative to the receiver +5V supply, or a 3K3 to the +12V supply.
- 3) Fit a 1.5K from the receive positive to the receiver supply Ground.

## Chapter 8 Trouble Shooting Guide

This chapter is designed to assist in the identification of problems relating to the installation and setting up of the LCA15.

### 1. General Connection and setup parameters. - No display on power up.

- a) Check supply is present at the LCA15 terminals.
- b) If supply is correct contact distributor.

Display shows (-1 or 1) continually, without a weight applied to the Strain Gauge.

- a) Check input connections to the LCA15 from the Strain Gauge.
- b) If connecting a 4 wire device ensure terminals 1&2 and 5&6 are linked.
- c) Check Strain Gauge output between input terminals 3&4 of the LCA15.
- d) Check that the CALH weight is applied and is not the same or lower than CALL

Display over ranges (-1 or 1) when, or before, the maximum required weight is applied to the Strain Gauge.

- a) Check output of Strain Gauge is set to the correct sensitivity settings on the DIL switch

Display very noisy

- a) If using a 4 wire device ensure terminals 1&2 & 5&6 are linked.
- b) Check output voltage of Strain Gauge.

Display operating in wrong direction

- a) Check connections to input terminals 3&4 are correct way round.
- b) Check the type of Strain Gauge - compression or tension.

Unit will not auto calibrate

- a) Check that CALH is not zero and its weight is greater than CALL.
- b) Check that input is not overranged on CALH weight.

Unit will not Auto Tare

- a) Check dP code for correct setting.
- b) Check auto tare sequence, when selected from keypad, is completed within 1 second.

Access to parameters not possible beyond the PASSWORD (PASS)

- a) Check for special password if not (contact supplier) with your company then your supplier (Quote serial number as a reference.)

### 2. Relay Output Module Incorrect Relay Operation

- a) Check set point, in flight and hysteresis values are correct.
- b) Check latching and inversion settings in output action (OA) are correct.
- c) Check connections to output terminals.

Remote function (Auto Tare, Peak Hold / Latched, printer fails to operate)

- a) Check 'dP' for correct value to ensure desired function selected.

### 3. FAST MANTRABUS / ASCII Format - No Communications

- a) Check that a comms module is fitted.
- b) Check correct CP code is entered for required protocol.
- c) Check connections to LCA15 from IF25 are correct.
- d) Check IF25 green LEDs are on and RX LED is on and TX LED is off. Press TX TEST, TX LED should light.
- e) Check RS232 connections from the host to the IF25 are correct.
- f) Check SdSt, serial device station number is correct.
- g) Check Baud rate settings on LCA15's are correct for the host.
- h) Check host comms port is set to 8 bit word, 1 start bit, 1 stop bit, no parity.
- i) Check correct protocol is being observed by the host.

## Chapter 9 LCA15 Specifications

### Strain Gauge Input

Calibration	Automatic digital by use of keypad and 1 (or 2) known weights.
Auto Tare	Auto Tare values can also be viewed and manually changed if required. Auto tare value is retained on power down. Auto Tare is affected from the field terminals.
Sensitivity Range	$\pm 0.05$ to $200\text{mV/V}$ (Factory set to nom $2.5\text{mV/V}$ ). (DIL Switch Selectable) Preset to $\pm 2\%$
Excitation	10V DC nominal, 150mA maximum
Compensation	By $\pm$ sense wires to compensate for cable, connection volt drops and any variation in 10V supply.
Accuracy after user Autocal	90 days $\pm 0.08\%$ of reading $\pm 0.05\%$ of FS typical
Temp. Drift	$0.002\%$ /C typical @ $2.5\text{mV/V}$
Display Rate	Programmer keypad selectable between 0.1 and 25.6 seconds.
Display Average	Set by programmer keypad, up to 64 standard updates
Input Filtering	Response for $15\text{mV rms}$ at $50\text{Hz}$ signal applied on a $25\text{mV}$ Full Range Input will give 1 part in 1,500 display digit noise.

### DC Analogue Outputs

Range		Max Drive	Typical	Accuracy
MIN	MAX	Capability	% of reading	% of FSD
+4	+20mA	20V (1K)	$\pm 0.08\%$	$\pm 0.08\%$
0	+10V	2mA	$\pm 0.08\%$	$\pm 0.08\%$
Isolation:	$\pm 130\text{V RMS}$ or DC to any other port			

### Control / Alarm Relay Output

2 SPCO relays, SP1 and SP2

Contact Rating  $240\text{V @ }5\text{A AC}$

Setpoint, In Flight Compensation, Hysteresis, Latching and Relay Inversion are set digitally using programmer keypad and display, in engineering units.

Hysteresis value applies to both SP1 and SP2. (Fail safe operation by setting inversion to give normally energised operation).

Latching Reset By volt free contact to field terminals or by communication.

### The Communications Port Data

#### Operation

All LCA15 display data can be retrieved via communications port along with relay and EEPROM status.

All LCA15 user configurable data can be changed including EEPROM enable/display and relay reset. (LCA15 Station Number cannot be changed).

The LCA15 communications port provides for a 2 way data link. An intelligent host e.g. Personal Computer, Main Frame or PLC is able to acquire the LCA15's displayed value and read or modify the user configurable parameters, using any of the following:-

- RS232 - for a one to one communication (as in the case of a printer, PC or PLC).
- RS485 - for the connection of up to 25, LCA15 units on a single RS485 line.

- c) 20mA Current Loop - for up to 250, LCA15 units on a single RS232 line, via the IF25 interface. With high noise immunity and isolation over distances up to 1Km.

Protocols available are ASCII and MANTRABUS selectable by the CP mnemonic on the display of the LCA15 programmer.

### *Data Retention and Protection*

Retention: 10 years for set values, minimum of 10,000 write cycles, but typically 1,000,000.

Protection of data and function(s): Watchdog timer giving repeat auto resets.  
Impending power fail detection and shutdown. Low power detection and hold off.

### *Environmental*

Storage temperature -20 to +70 °C

Operating temperature -10 to +50 °C

Relative humidity 95% max non condensing

Front panel sealing To IP65

EMC Immunity

EN 50 081-1 :1992  
EN 50 082-1 :1992  
(RF Field Test :0.05% FS except 0.2% @ 50-120MHz)  
pr EN 50 093 :1991, superceded by :  
IEC 1000-4 Section 11, 1994

Low Voltage Directive

EN 61000-4-11

IEC 1010-1 :1990  
EN 61010 :1993

### *Physical*

Case dimensions 200 x 120 x 75mm

Case materials Light grey ABS

Weight 725g

Terminals 2.5mm, saddle field terminals

Accessibility All electronics accessible through front panel.

### *Power Supplies*

210 - 260v AC, 50 - 60Hz, 10W  
97 - 120v AC, 50 - 60Hz, 10W  
9 - 32v DC, 50 - 60Hz, 10W

## LCA15 Order Codes

<b>Input</b>	Standard Strain Gauge		10v DC / 150mA	] LCA15
<b>Outputs</b>	Standard Analogue	Output DC voltage DC current	Range 0v to 10v 4 to 20mA	
<b>Optional Modules</b>				
<b>Communications Port</b>		Current Loop Printer RS232 RS485		(LC1) (LC3)
<b>Output</b>	Control/Alarm Relay	Output 2 Relays	Function SPCO on SP1 & 2	(LR1)
<b>Power Supplies</b>		220 - 240v AC 50 - 60Hz 10W		
		110 - 120v AC 50 - 60Hz 10W		(LS1)
		9 - 32V DC 50 - 60Hz 10W		(LS3)
<b>Program Units</b>		On Board		(LP1)
		Remote Hand Held		(LP2)

**Example:** (LCA15 - LR1 - LC2 - LS1)

Standard LCA15 with relay module and RS232 Communications and 110/240 volts AC power supply

### LCA15 Accessories

The following accessories are available to allow for expansion of systems:

	<b>Function</b>	<b>Order Code</b>
<b>IF25 Interface</b>	Connect up to 25 LCA15s NOTE: Details of the unit appears in a separate publication.	IF25
<b>Printers</b>	Time / date and display data Display data only	TDP DP

## Instrument Setup Record Sheet

Product
Product Code
Serial No
Tag No
Date
Location
Measurement type, range & engineering units
Communication / Baud Rate

LCA15	Value
PASS	
SP1	
IF1	
SP2	
IF2	
HYS	
OA	
CALL	
CALH	
At	
dA	
OPL	
OPH	
dP	
CP	
SdSt or LAb	
Ln (for printer)	
rS	

## WARRANTY

All LCA products from Mantracourt Electronics Ltd., ('Mantracourt') are warranted against defective material and workmanship for a period of (3) three years from the date of dispatch.

If the 'Mantracourt' product you purchase appears to have a defect in material or workmanship or fails during normal use within the period, please contact your Distributor, who will assist you in resolving the problem. If it is necessary to return the product to 'Mantracourt' please include a note stating name, company, address, phone number and a detailed description of the problem. Also, please indicate if it is a warranty repair.

The sender is responsible for shipping charges, freight insurance and proper packaging to prevent breakage in transit.

'Mantracourt' warranty does not apply to defects resulting from action of the buyer such as mishandling, improper interfacing, operation outside of design limits, improper repair or unauthorised modification.

No other warranties are expressed or implied. 'Mantracourt' specifically disclaims any implied warranties of merchantability or fitness for a specific purpose. The remedies outlined above are the buyer's only remedies. 'Mantracourt' will not be liable for direct, indirect, special, incidental or consequential damages whether based on the contract, tort or other legal theory.

Any corrective maintenance required after the warranty period should be performed by 'Mantracourt' approved personnel only.



© In the interests of continued product development, Mantracourt Electronics Limited reserves the right to alter product specifications without prior notice

Doc No. ME 0069 ML 1D	Code No. 517-070	Issue 3.8	05.02.07
-----------------------	------------------	-----------	----------