



DSCUSB Toolkit Manual Strain Gauge or Load Cell Digitiser Module



User Manual
www.mantracourt.co.uk

ME mantracourt

Contents

Chapter 1 Introduction	2
Overview	2
Chapter 2 Getting Started	3
Communications Interface Information	3
DSC Toolkit	3
What Can The Toolkit Do?	3
Installing DSC Toolkit	3
Found New Hardware Wizard	4
Connecting up the Device	8
Using the Software	8
Chapter 3 Explanation of Filter	17
Dynamic Filtering, Filter Level & Filter Steps	17
Chapter 4 Installation	19
Before Installation	19
Identifying Strain Gauge Connections	20
4-wire load cell	20
6-wire load cell	20
Chapter 4 Specifications	21
Technical Specifications DSCUSB	21
Environmental Approvals	22
Warranty	22

Chapter 1 Introduction

This chapter provides an introduction to the DSCUSB products, describing the product range and main features.

Overview

The DSCUSB products are high-precision Strain Gauge Converters; converting a strain gauge sensor input to a digital USB serial output. They allow high precision measurements to be made and communicated directly to a PC. With the appropriate drivers installed, the DSCUSB appears as a virtual communication port to the PC .



Free-standing module fitted with 9-way 'D' type socket for load cell, temperature and digital I/O connections. Integral USB lead with type 'A' connector.

Dimensions:

Case: 86 x 57 x 26.5mm excluding connector (95mm (3.740") including 9-way 'D' type socket) with 136cm (4.462 feet) USB cable.

Chapter 2 Getting Started

Please ensure that software is installed before connecting the device to your PC

This chapter explains how to connect to a DSCSUEASC for the first time and how to get it working. The ASCII version is supported by a Toolkit software application that is simple to use. If you have any other type of device you must use Instrument Explorer to configure the device.

Note that Instrument Explorer can be used with ASCII devices as well, so if you need more complex configuration than DSC Toolkit offers you can use Instrument Explorer. This can be downloaded from our website at www.mantracourt.co.uk and is supported by an alternative manual, DSC USB (517-180) which can also be downloaded from our website

Communications Interface Information

DSCUSB devices can connect to a PC by plugging into a USB port and do not require an external power supply as they appear as a 'single unit load' i.e. they draw <100mA.

Appropriate drivers must be installed which are bundled with the DSC Toolkit. These create a virtual serial port allowing the DSCUSB to appear to the PC as a normal COM port device.

DSC Toolkit

DSC Toolkit is a simple configuration tool designed specifically for configuring ASCII DSCs. If you have a device with a different communications protocol you will have to use Instrument Explorer.

This toolkit allows configuration, calibration, logging and parameter management of the DSCSUEASC modules.

What Can The Toolkit Do?

- Viewing of input with enunciators for integrity and range errors.
- Two point auto calibration by application of known weight.
- Setting System Zero and under and over range limits.
- Select measurement rate and filter settings.
- Save device settings including user calibration and ability to restore to same or different USB DSC modules.
- Log input value to a CSV file at up to 100Hz which can be analysed in Microsoft Excel.

Installing DSC Toolkit

Install the DSC Toolkit software by inserting the CD in the CD ROM drive. This should start the 'AutoRun' process, unless this is disabled on your computer.

(If the install program does not start of its own accord, run SETUP.EXE on the CD by selecting 'Run' from the 'Start Menu' and then entering D:\SETUP, where D is the drive letter of your CD-ROM drive).

During installation of the DSC Toolkit or the Instrument Explorer software you will see a dialog box appear stating that an unsigned driver is being installed. Select 'Continue Anyway' to indicate that this is OK. The installation software is trying to pre-install the required drivers so that they can be automatically found when the hardware is plugged in later on.

This will appear twice during the installation.



Found New Hardware Wizard

After installing the software you can connect the DSCUSB device to the computer.

The 'Found New Hardware Wizard' should now appear.

Select 'No, not at this time' so that the wizard does not try searching online for a driver. Click 'Next'.



32 bit Operating Systems

If you have a 32 bit version of Vista or a 32 bit version of Windows 7 or XP then select 'Install the software automatically (Recommended)' and click 'Next'.

64 bit operating Systems

For those of you with 64 bit Vista or 64 bit Windows 7 you have to point the wizard to the driver location. So select 'Install from a list or specific location' and follow the prompts until you can select a folder to look in. The folder you need to navigate to is C:\Program Files (x86)\DSCU Drivers\.



Now the wizard will start searching for the drivers.



You will see a warning that the driver is unsigned. This is normal and you should choose to 'Continue Anyway'.



Depending on your operating system the above message may appear as follows:



The wizard should then proceed with installing the software drivers.



Please note that there are two interfaces to the hardware so that there are two drivers that will be installed

The USB DSC Port and the USB DSC Bus.

So the next dialog box you will see will be for the USB DSC Port and the steps will be repeated from step 2.



Connecting up the Device

Simply connect to a spare USB port on the PC using the lead provided in the kit.

Using the Software

The DSC Toolkit automatically detects the connected DSCs so you do not need to worry about baudrates, station numbers or COM port numbers.

If there is only one USB DSC connected when you launch the DSC Toolkit it will be automatically selected and the Information Page will be displayed.

If multiple devices are detected you will be presented with a list to choose from on the Home Page.

To connect to a device just click on it in the list and click the 'Connect' button (Or just double click the device in the list).

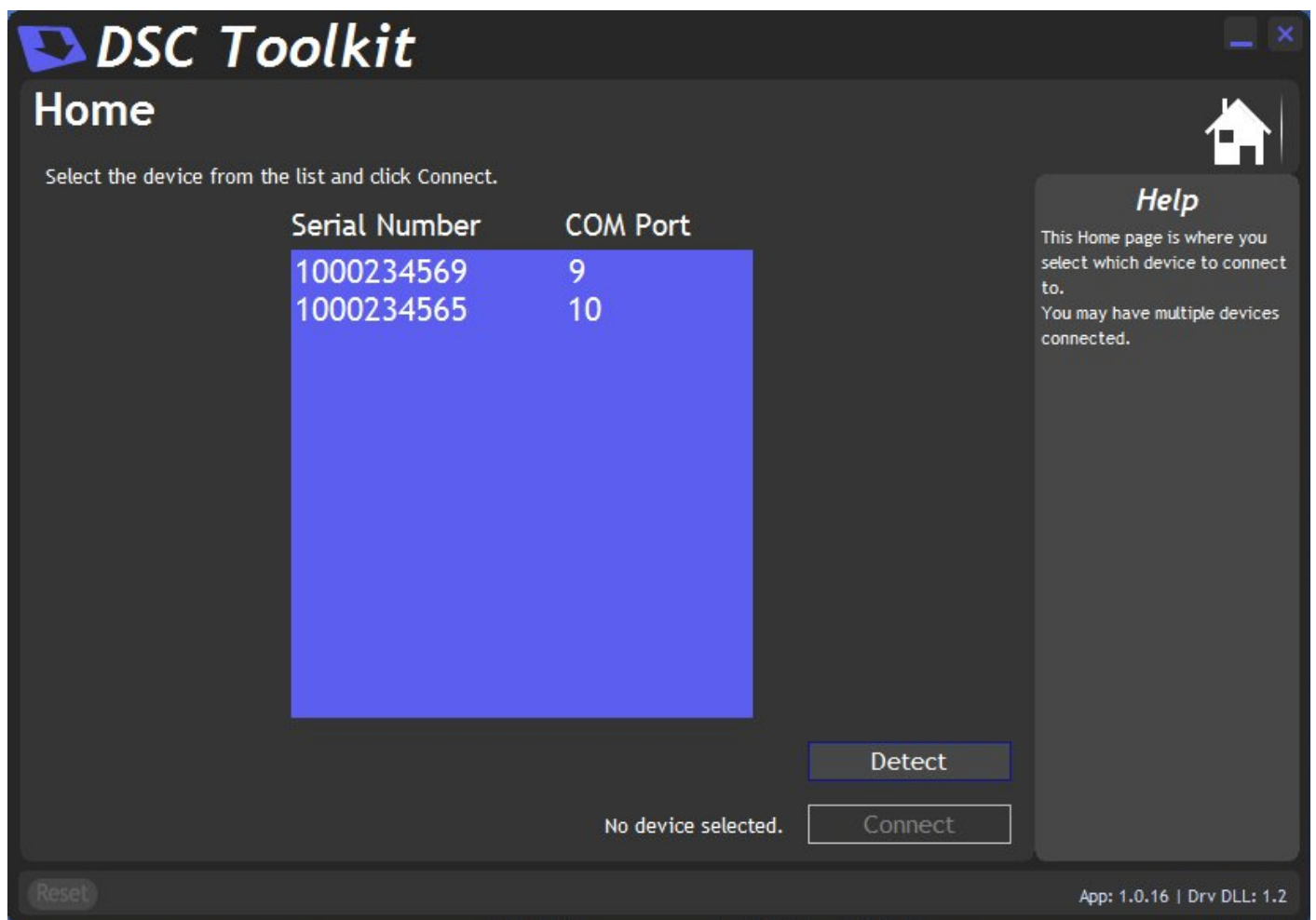

You will then see the Information page.

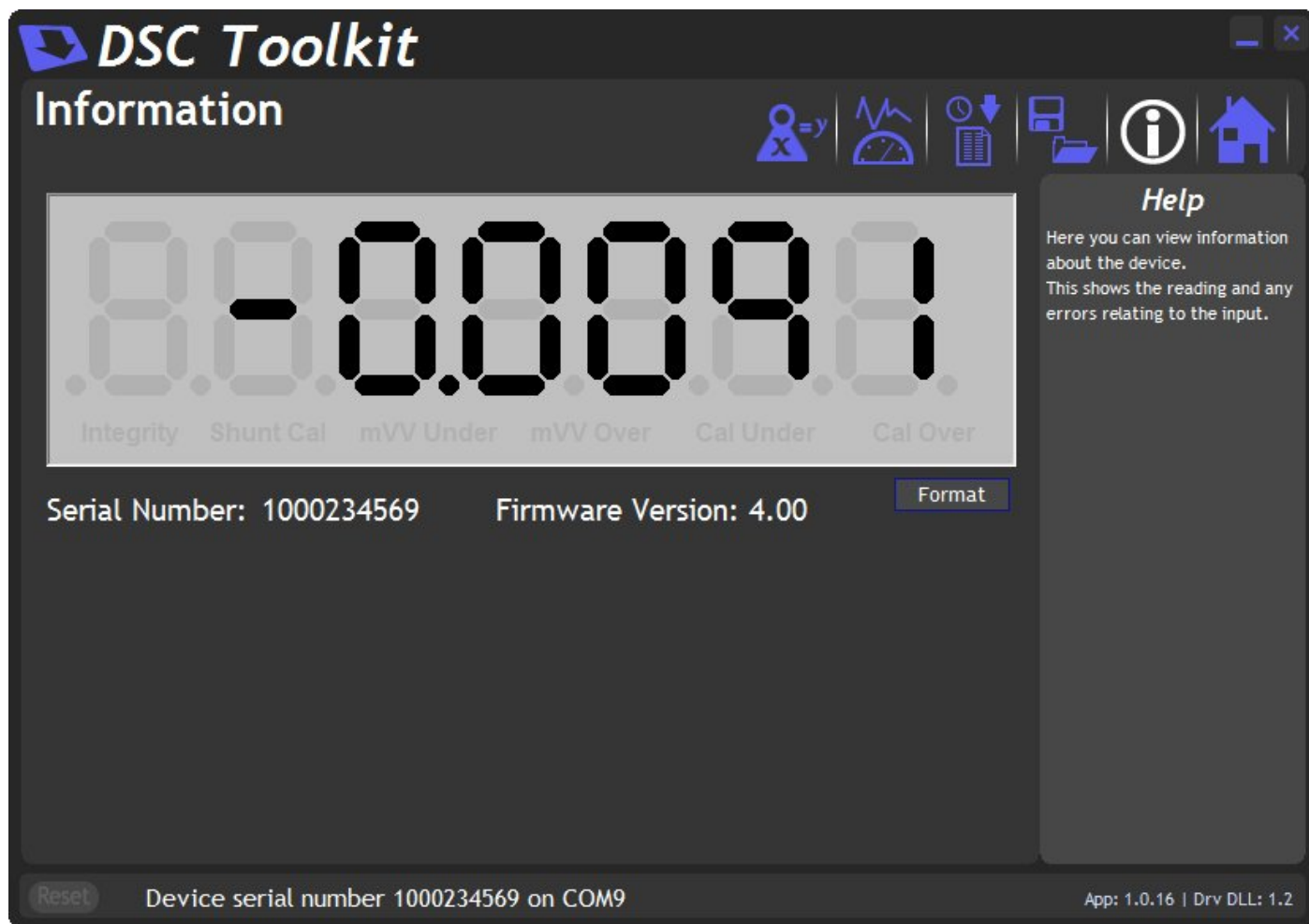

This simply shows a large display and indicates if any error conditions are present by displaying an information box.

The following screenshot shows an Integrity error present.

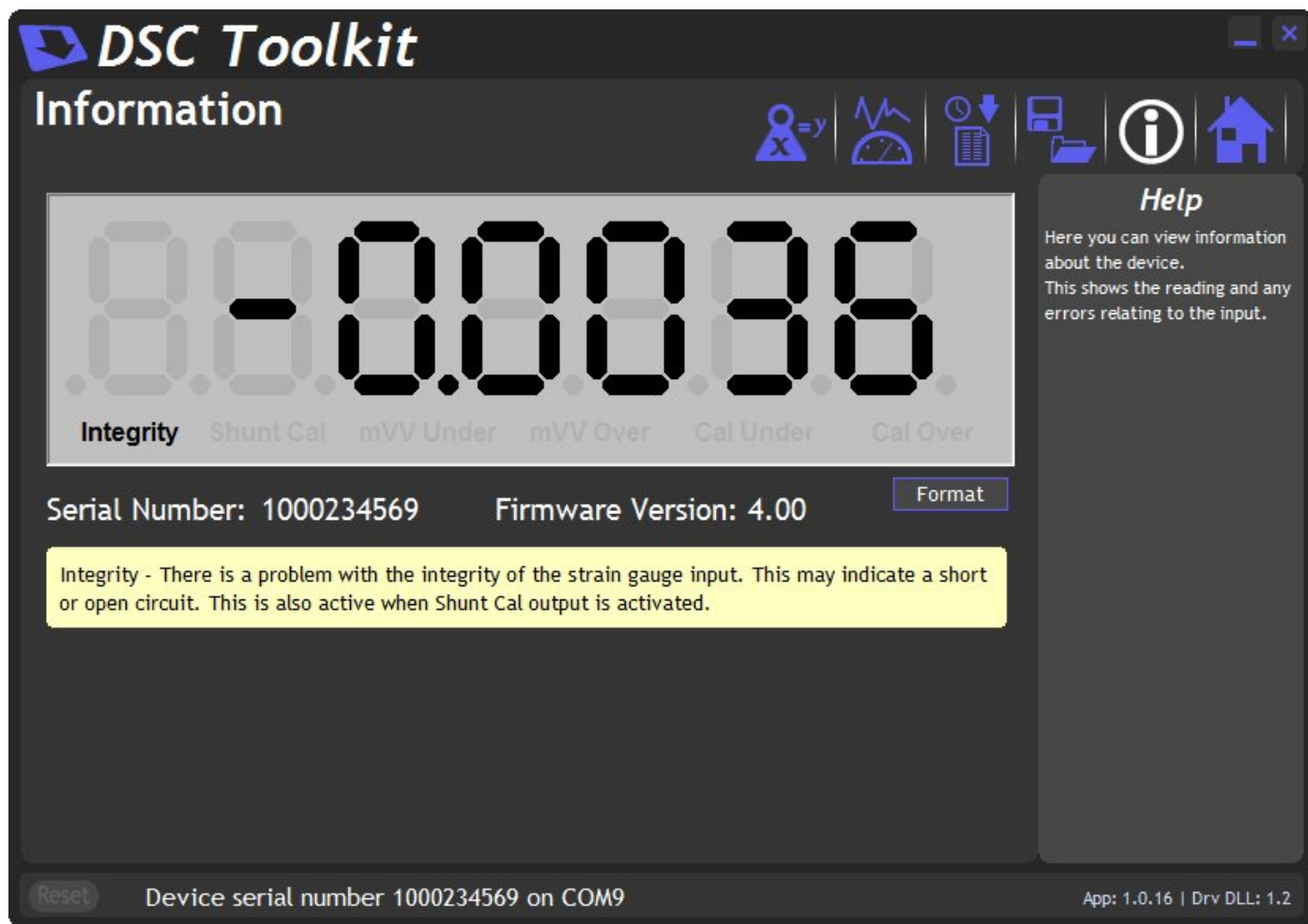

The error box will disappear once the error is no longer present.

Clicking the 'Format' button allows you to select a new format for the displayed value. By using this you can hide unwanted decimal places.

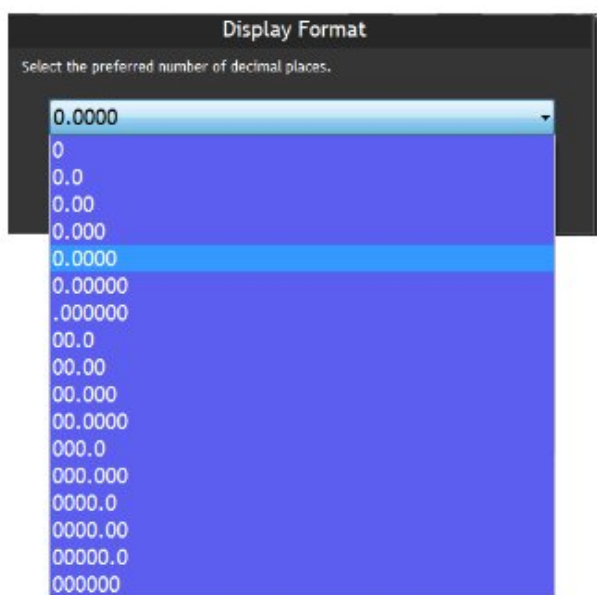

Just click the required display format in the list.



To select a different device just click the Home icon

Home Page

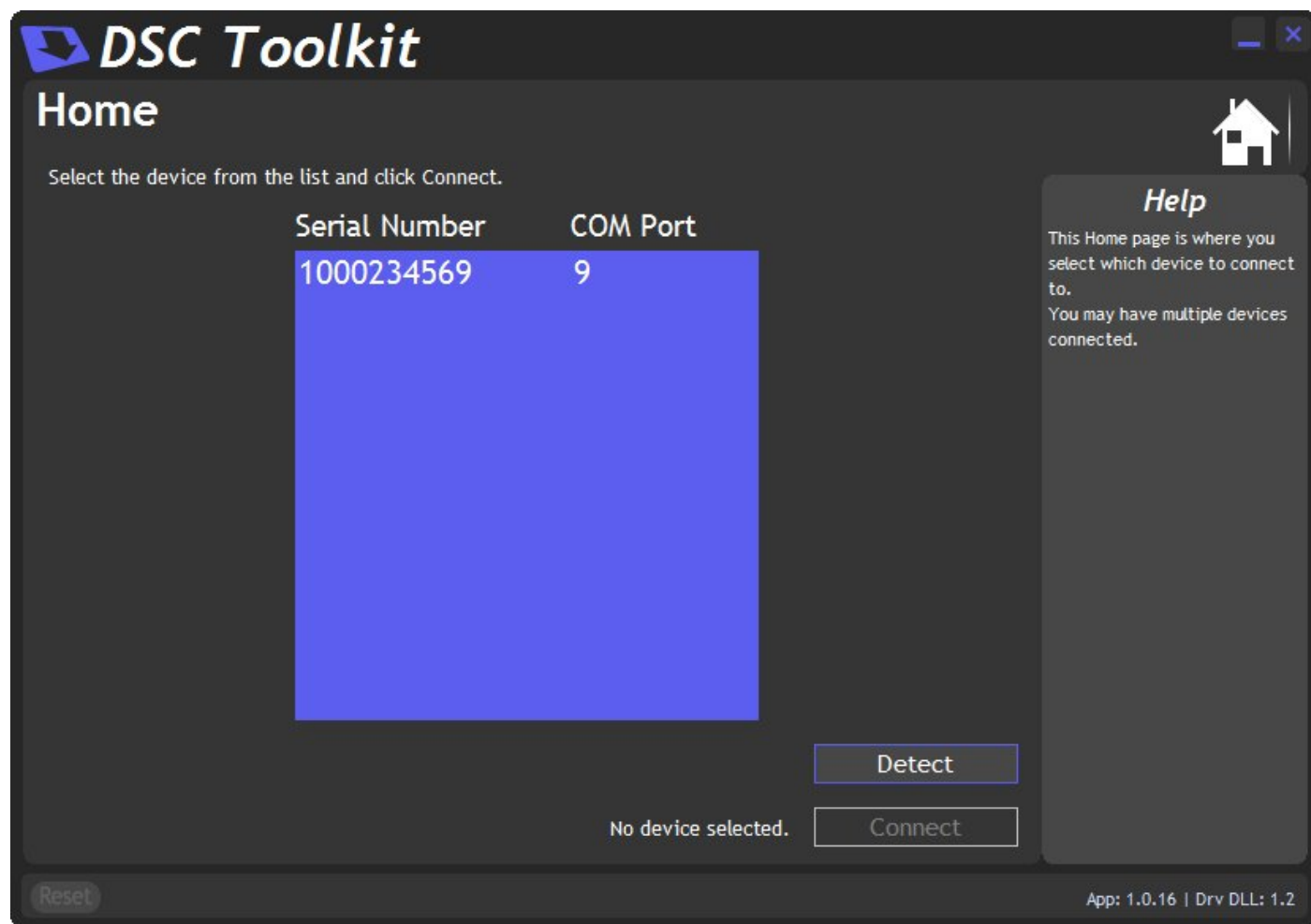

You can then select a different device or plug in a different device. If you change the connected devices click the 'Detect' button to re-list the devices. Then select the required device from the list.



Click on the icon to open the Save & Restore page.

Save And Restore Page



Clicking the 'Save' buttons will allow you to specify a file to which the configuration of the connected device is written.

Once saved this file can be selected, after clicking the 'Restore' button, and the settings restored to the same device or to another device.



Click on the icon to open the Data Rates & Filter page.

Data Rates And Filter Page

This page allows you to select the measurement rate and filtering characteristics. The measurement rate affects the noise free resolution which is indicated at the bottom of the page.

The filter level and filter steps affect the frequency response of the input which is indicated at the bottom of the page.

See Chapter 3 - Explanation of Filter



Click on the icon to open the Calibration page.

Calibration Page

DSC Toolkit
Calibration

mV/V Input: -0.00356
Shows the input applied.

Calibrated Value: -0.0036
Shows the calibrated value. This may not display correctly until you have Acquired the second point!

2 Point Calibration
1: 0.0000 [Acquire] Enter the engineering units required at 2 points. Apply these inputs then click the Acquire button in sequence.
2: 0.0000 [Acquire]
Revert to factory default calibration [Reset]

System Zero
To perform System Zero [Zero] To remove System Zero [Remove]

Shunt Calibration
Activate Shunt Cal [Turn On]

Over & Under-range Limits
Cal Under (SMIN): -100.0
Cal Over (SMAX): 100.0
Set the minimum and maximum input values in calibrated engineering units. When the input falls outside these limits the Cal Under or Cal Over indicators will be displayed on the Information screen.

Help
This page allows you to apply a two point calibration.
Enter the required engineering unit value for each point then apply the input and click the [Acquire] button. Calibrating will remove system zero.
Note that when calibrating the Cal Under and Over limits may be modified if they are deemed to be incorrect. You may alter them again after calibration.

[Reset] Device serial number 1000234569 on COM9 App: 1.0.16 | Drv DLL: 1.2

This page allows you to calibrate the device, set limits and perform system zero.

2 Point Calibration

The automatic calibration requires that you apply two known (ascending) weight in sequence. Just enter the required engineering unit value for the two weights in the fields marked 1 and 2. Next, apply the low weight and allow a settle time. Click the 'Acquire' button then apply the high weight. After another settle time click the second 'Acquire' button and the calibration is complete.

System Zero

To remove the current weight on all subsequent readings click the 'Zero' button. Click the 'Remove' button to return to displaying the actual weight applied. This system zero is stored in the device and remains through power cycling.

Shunt Calibration

Click the 'Turn On' 'Turn Off' button to toggle the shunt calibration output. The shunt cal internally connects a resistor across the strain gauge bridge. This can be used to quickly verify the gain settings of the device.

Over & Under-range Limits

Here you can set limits below and above which the warning indicators will be displayed on the Information Page.



Click on the icon to open the Logging page.

Logging Page

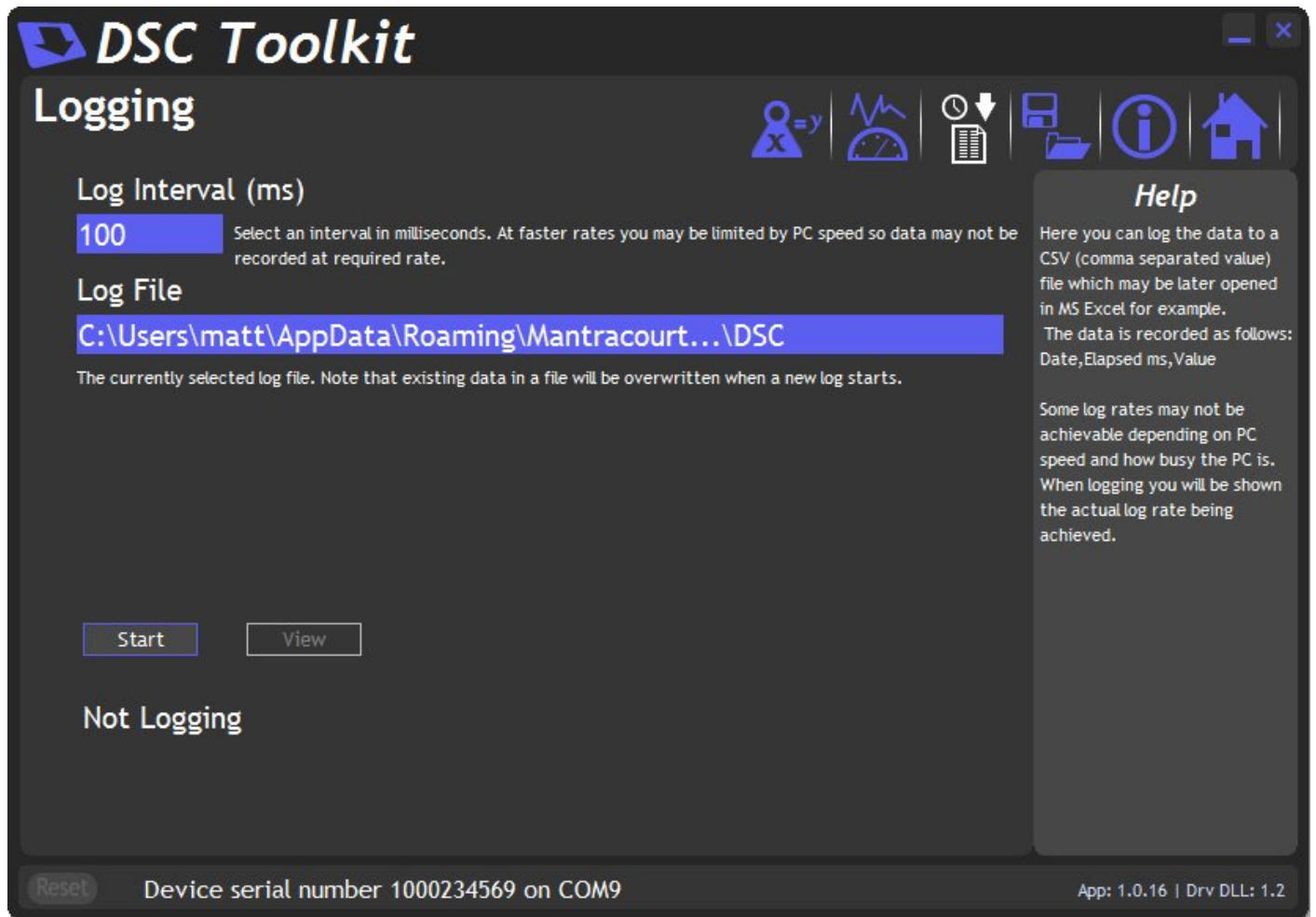

The toolkit allows you to log data to a CSV (Comma Separated Value) file. This file will open in MS Excel when double clicked.

Log Interval

Choose a Log Interval in milliseconds between 10 and 32000. 10mS will enable a log at 100Hz.

Log File

Select a file to log to. Note that each time the log starts it will erase any data already in the file.

Start

Clicking this button will start the log.

Stop

Clicking this button will stop the log.

View

When a log has just been stopped this button will launch the application associated with CSV files.

The format of the log file is as follows:

DateTime, Elapsed, Value

Where:

DateTime is the date and time in long format

Elapsed is the time elapsed in milliseconds since the start of the log

Value is the numeric value logged

Example

```
08/06/2009 15:41:08,0,-3.25300008989871E-03
08/06/2009 15:41:08,10,-3.25300008989871E-03
08/06/2009 15:41:08,43,-3.25300008989871E-03
08/06/2009 15:41:08,60,-3.25300008989871E-03
```

If the measurement rate of the device is less than the rate at which you have chosen to log you will be informed with a message as shown below.

Either reduce the Log Interval or reduce the Measurement Rate.

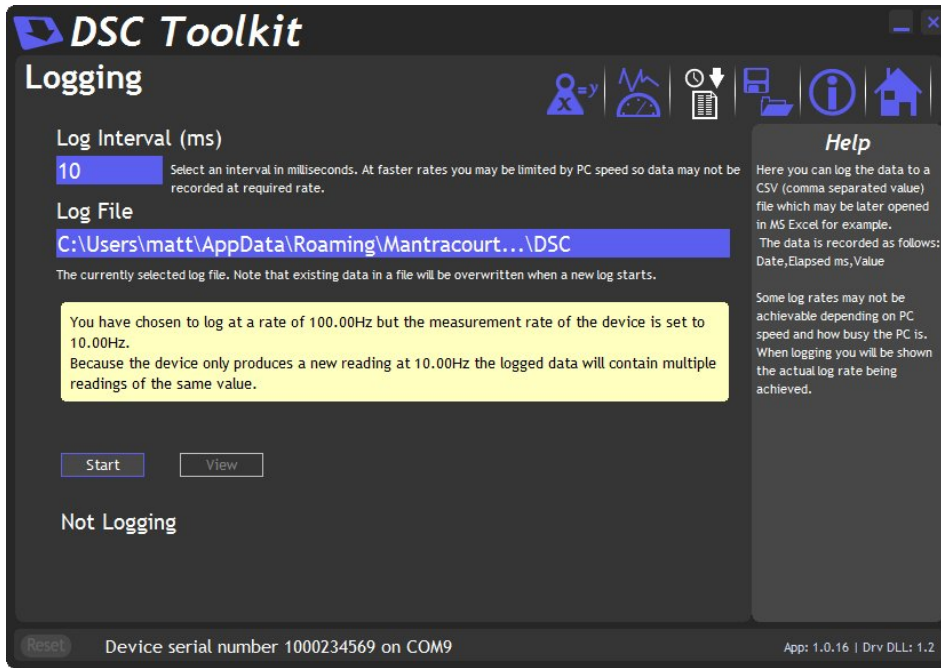

Once the logging starts the actual achieved log rate will be displayed at the bottom of the window. This is useful for diagnostics such as when a heavily burdened PC is slowing the log rate.

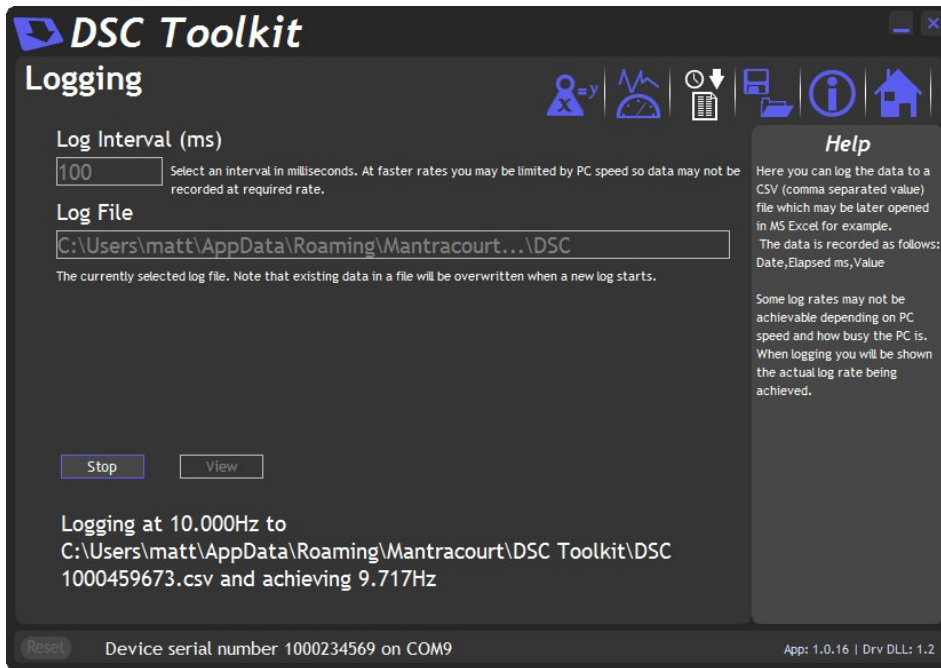

Chapter 3 Explanation of Filter

Dynamic Filtering, Filter Level & Filter Steps

The Dynamic filter is basically a recursive filter and therefore behaves like an 'RC' circuit. It has two user settings, a level set in mV/V and the maximum number of steps (up to 255).

Instead of outputting every new value, a fraction of the difference between the new input value and the current filtered value is added to the current filtered value to produce the filtering action.

If this difference is less than the value set in the Filter Level then the fractional amount added each time is decremented until it reaches the minimum level set by FFST i.e. FFST is the limit of the divisor.

e.g. if Filter Steps = 10 the fractional part of the difference between the new value and the current filtered value will be decremented as follows: 1/1, 1/2, 1/3, 1/4, 1/5, 1/6 . . . 1/10, 1/10, 1/10 before being added to the current filtered value.

If a rapidly changing or step input occurs and the difference between the new input value and the current filtered value is greater than the value set in Filter Level then the output of the filter will be made equal to the new input reading i.e. the fractional amount of the new reading added to the current reading is reset to 1

This allows the Filter to respond rapidly to fast moving input signals.

When a step change occurs which does not exceed Filter Level, the new filtered value is calculated as follows:

New Filter Output value = Current Filter Output Value + ((Input Value - Current Filter Output Value) / Filter Steps)

The time taken to reach 63% of a step change input (which is less than Filter Level) is the frequency at which values are passed to the dynamic filter, set in Measurement Rate, multiplied by Filter Steps.

The table below gives an indication of the response to a step input which is less than Filter Level.

% Of Final Value	Time To settle
63%	Measurement Rate * Filter Steps
99%	Measurement Rate * Filter Steps * 5
99.9%	Measurement Rate * Filter Steps * 7

For example, If Measurement Rate is set to 100Hz = 0.01s and Filter Steps is set to 30 then the time taken to reach a % of step change value is as follows.

% Of Final Value	Time To settle
63%	0.01 x 30 = 0.3 seconds
99%	0.01 x 30 x 5 = 1.5 seconds
99.9%	0.01 x 30 x 7 = 2.1 seconds

The following table shows the number of updates '**x Filter StepsT**' and the '**% Error**' that the **Filtered Output value** will differ from the constant **Input Value**.

x FFST	% Error
1	36.78794412
2	13.53352832
3	4.97870684
4	1.83156389
5	0.67379470
6	0.24787522
7	0.09118820
8	0.03354626
9	0.01234098
10	0.00453999
11	0.00167017
12	0.00061442
13	0.00022603
14	0.00008315
15	0.00003059
16	0.00001125
17	0.00000414
18	0.00000152
19	0.00000056
20	0.00000021

Remember: if the step change in mV/V is greater than the value set in Filter Level then:
 New Filter Output value = New Input Value i.e. the output jumps to the new input value and the internal working value of Filter Steps is reset to 1. This is then incremented each update (set by Measurement Rate) until it reaches the user set value of Filter Steps.

Chapter 4 Installation

This chapter gives detailed information on integrating the DSCUSB into a production system - including mounting, protection, adjustments, wiring and electrical requirements.

Before Installation

Carefully remove the DSCUSB device from its shipment box. Check that the device is complete and undamaged. Check the Product Type Code - on the product label is that which you ordered.

The DSCUSB can operate in any industrial environment providing the following limits are not exceeded

Operating Temperature	-40 °C to +85 °C
Humidity	95% non condensing
Storage temperature	-40 °C to +85 °C

Identifying Strain Gauge Connections

4-wire load cell

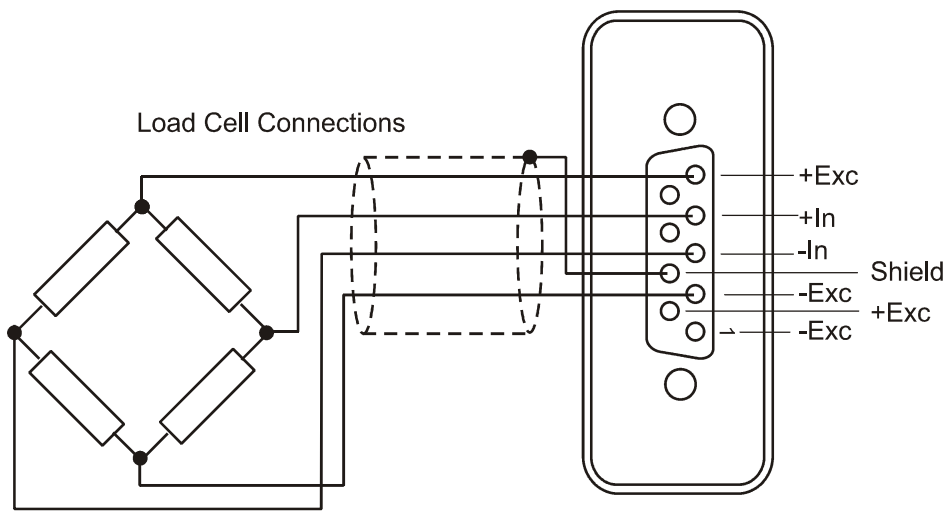

6-wire load cell

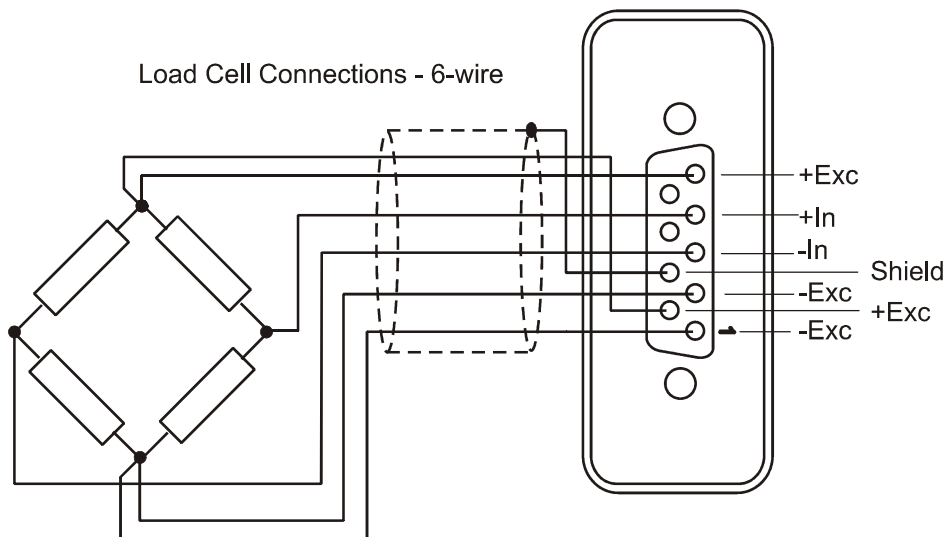

Chapter 4 Specifications

Technical Specifications DSCUSB

The DSCUSB is factory set for 2.5mV/V sensitivity.

Parameter	Min	Typical	Max	Units
Strain Gauge Excitation System	4 Wire			
Strain Gauge Excitation Voltage	4.5	5	5.25	VDC
Strain Gauge Drive Capability	80	-	5000	Ohms
Strain Gauge Sensitivity	-3	2.5	3	mV/V
Offset Temperature Stability		5	10	ppm/C
Gain Temperature Stability		30	50	ppm/C
Offset Stability with Time		35	160	ppm of FR (1)
Gain Stability with Time			300	ppm of FR (2)
Non Linearity before Linearization		5	25	ppm of FR
Internal Resolution		16 Million		Counts/divs
Resolution @ 1Hz readings (Noise stable) over 100s		66,000		Counts/divs
Resolution @ 10Hz readings (Noise stable) over 100s		40,000		Counts/divs
Resolution @ 100Hz readings (Noise stable) over 100s		10,000		Counts/divs
Resolution @ 500Hz readings (Noise stable) over 100s		5,000		Counts/divs
Signal Filter	Dynamic recursive type user programmable			
Electrical				
Power Supply voltage	4.25	5	5.5	V dc
Power Supply current (350 Ohm Bridge)		68	75	mA
Data transmission				
Data transmission rate	2.4	-	460.8	kbps
Output cable length (speed dependant)			5	m
Environmental				
Operating temperature range	-40		+85	C
Storage temperature	-40		+85	C
Humidity	0		95	%RH
Dimensions				
Cased version	86 x 57 x 26.5mm (3.3465 x 2.2492 x 1.087") excluding connector (95mm 3.740") including 9-way 'D' type connector) with 136 cm 94.462 feet USB cable.			

Notes.

1. From original offset at any time
2. 1st Year

Environmental Approvals

CE Approvals

European EMC Directive 2004/108/EC
 BS EN 61326-1:2006
 BS EN 61326-2-3:2006

Output shall not exceed the sum of uncertainties when subjected to an electric field of 10V/m over the frequency range 80 to 600MHz

Warranty

All DSC products from Mantracourt Electronics Ltd., ('Mantracourt') are warranted against defective material and workmanship for a period of (3) three years from the date of dispatch.

If the 'Mantracourt' product you purchase appears to have a defect in material or workmanship or fails during normal use within the period, please contact your Distributor, who will assist you in resolving the problem. If it is necessary to return the product to 'Mantracourt' please include a note stating name, company, address, phone number and a detailed description of the problem. Also, please indicate if it is a warranty repair.

The sender is responsible for shipping charges, freight insurance and proper packaging to prevent breakage in transit.

'Mantracourt' warranty does not apply to defects resulting from action of the buyer such as mishandling, improper interfacing, operation outside of design limits, improper repair or unauthorised modification.

No other warranties are expressed or implied. 'Mantracourt' specifically disclaims any implied warranties of merchantability or fitness for a specific purpose. The remedies outlined above are the buyer's only remedies. 'Mantracourt' will not be liable for direct, indirect, special, incidental or consequential damages whether based on the contract, tort or other legal theory.

Any corrective maintenance required after the warranty period should be performed by 'Mantracourt' approved personnel only.



C
In the interests of continued product development, Mantracourt Electronics Limited reserves the right to alter product specifications without prior notice.

DESIGNED & MANUFACTURED IN THE UK

Code No 517-916

Issue 1.0

12.06.09