

F310

Axial Force And Torque Transducer

Range $\pm 50\text{N}$ and 2Nm

- ◆ Low cross talk
- ◆ Custom ranges
- ◆ Simple installation
- ◆ Direct outputs without calculation
- ◆ Standard 2 year warranty

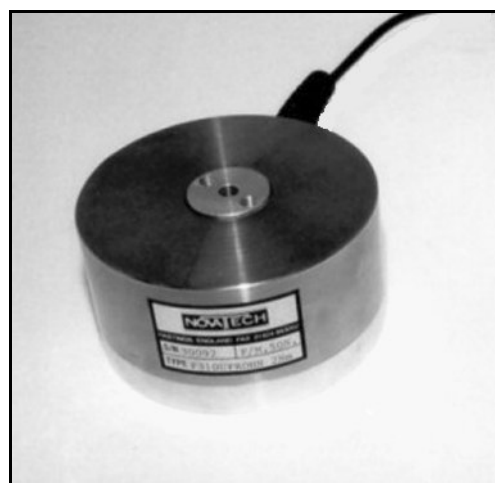

Geometry: Monocoque strain structure with no moving parts.

The F310 depicted measures force and torque in the same axis with minimal cross talk providing user friendly outputs for direct measurement without mathematical manipulation.

Each channel may be calibrated bi-directionally. The version of the transducer depicted was developed for an OEM producing texture analyser machines (rheometers) for use in the food process industry.

We are happy to design variants of this loadcell to meet your specific requirements. Variants may include different combinations of force and moment axis e.g. F_xM_z , F_yM_x , F_zM_y etc.

Details of our other loadcell families can be found in the Loadcell Specifier Guide. If you require a copy please contact our sales department or look on our web site at www.novatechloadcells.co.uk.

Ordering Codes:	See the ordering code sheet for more details. Add ranges in the required units.
------------------------	---

Most F310 transducers are manufactured to special requirements and are given an F310-Zxxxx number.	
--	--

F310 Specification

Parameter	Value	Unit
Non-linearity - Terminal	±0.05	% RL
Hysteresis	±0.05	% RL
Creep - 5 minutes	±0.1	% AL
Repeatability	±0.05	% RL
Maximum cross talk	1	% RL
Rated output - Nominal	0.6	mV/V
Rated output - Rationalised	0.5	mV/V
Rationalising tolerance	±0.5	% RL
Zero load output	±4	% RL
Temperature effect on rated output per °C	±0.005	% AL
Temperature effect on zero load output per °C	±0.02	% RL
Temperature range - Compensated	-10 to +50	°C
Temperature range - Safe	-10 to +80	°C
Excitation voltage - Recommended	10	V
Excitation voltage - Maximum	10	V
Bridge resistance	350	Ω
Insulation resistance - Minimum at 50Vdc	500	MΩ
Overload - Safe	50	% RL
Overload - Ultimate	300	% RL
Sealing	IP65	
Weight - Nominal (excluding cable)	250	g

The standard range is manufactured in aluminium.

Notes

1. AL = Applied load.
2. RL = Rated load.
3. Temperature coefficients apply over the compensated range.
4. Values apply to force and moment in all load combinations.

Connections

The F310 is fitted with 2 metres of PVC insulated 9 core screened cable type 7-1-9C. The screen is not connected to the loadcell body.

Function	Wire Colour	
	Fz	Mz
Excitation +	Red	Violet
Excitation -	Blue	Black
Signal +	Yellow	Brown
Signal -	Green	White
Screen	Orange	

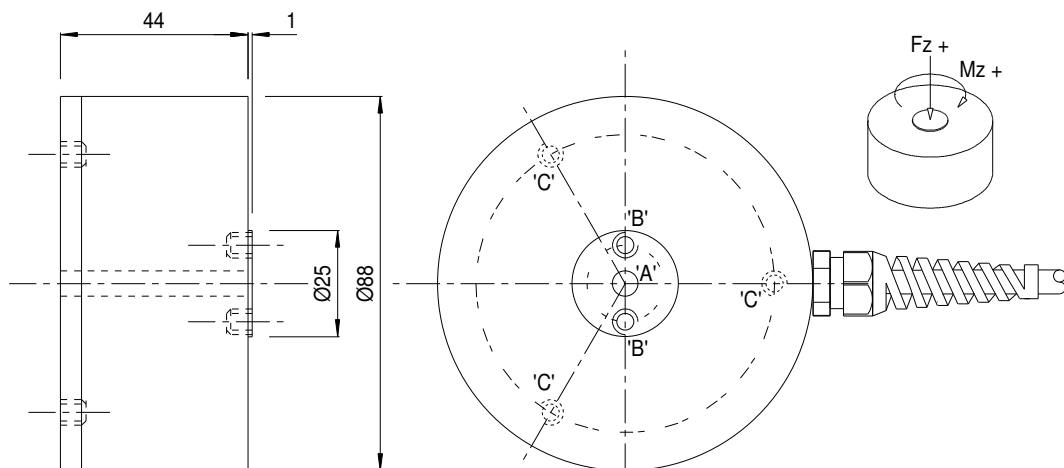

'A' Ø6 THRO. 'B' M6x1 ON A 18 PCD - 2 OFF. 'C' M6x1 EQUI SPACED ON A 70 PCD - 3 OFF

Novatech reserves the right to vary the foregoing details without prior notice

01/2008

NOVATECH MEASUREMENTS LTD

83 CASTLEHAM ROAD, ST LEONARDS ON SEA, EAST SUSSEX, TN38 9NT, ENGLAND

Tel: 01424 852744

email: info@novatechloadcells.co.uk

Fax: 01424 853002

www.novatechloadcells.co.uk