



F209

Donut Loadcell

Standard Ranges 100, 200 and 400tonne (1000 to 4000kN)

- ◆ **Hardened stainless steel body**
- ◆ **Very high structural load limit**
- ◆ **Standard 2 year warranty**
- ◆ **Tensile applications are ‘fail-safe’**
- ◆ **Flying lead or connector option**



Geometry: Axial strain cylinder in a sealed case, with raised end load bearing faces and hole right through. For use in compression or in fail-safe tensile applications.

The F209 is ideally suited to engineering force measurements including through centre safety testing of cables, rods and bolts.

It is designed for easy installation, usually between two flat faces bearing on its loading rings, either unattached or with retaining spigots positioned in the centre hole. Alternatively tensile load transfer can be achieved via a tie rod assembly through the centre hole. In this way the loadcell can indirectly measure tensile loads in a “fail-safe” mode.

We are happy to design variants of this loadcell to meet your specific requirements. Please consult our engineering department.

Details of our other loadcell families can be found in the Loadcell Specifier Guide. If you require a copy please contact our sales department or look on our web site at www.novatechloadcells.co.uk.

Ordering Codes:	See the loadcell ordering code sheet for more details. Add range in the required units.		
F209CFR0H0	Compression, IP65, unrationalised		
Change the F to a P for the connector version.			

F209 Specification

Parameter	Value	Unit
Non-linearity - Terminal	±1.0	% RL
Hysteresis	±1.0	% RL
Creep - 20 minutes	±0.1	% AL
Repeatability	±0.02	% RL
Rated output - Nominal	1.2	mV/V
Zero load output	±4	% RL
Temperature effect on rated output per °C	±0.005	% AL
Temperature effect on zero load output per °C	±0.03	% RL
Temperature range - Compensated	-10 to +50	°C
Temperature range - Safe	-10 to +80	°C
Excitation voltage - Recommended	10	V
Excitation voltage - Maximum	10	V
Bridge resistance	350	Ω
Insulation resistance - Minimum at 50Vdc	500	MΩ
Overload - Safe	50	% RL
Overload - Ultimate	400	% RL
Sealing	IP65	
Weight - Nominal (excluding cable)	7 to 9	kg

All standard ranges are manufactured in stainless steel.

Structural stiffness - Nominal					
Range (kN)	Stiffness (N/m)	Range (kN)	Stiffness (N/m)	Range (kN)	Stiffness (N/m)
1000	4.0×10^{10}	2000	8.0×10^{10}	4000	1.6×10^{11}

Notes

- AL = Applied load.
- RL = Rated load.
- Temperature coefficients apply over the compensated range.
- The load must be applied directly through the central loading axis.

Connections

The loadcell is fitted with 2 metres of PVC insulated 4 core screened cable type 16-2-4C or a 4 pin Binder 723 series chassis plug.

Excitation + = Red or pin 1

Signal + = Yellow or pin 3

Screen = Orange

Excitation - = Blue or pin 2

Signal - = Green or pin 4

The screen is not connected to the loadcell body.

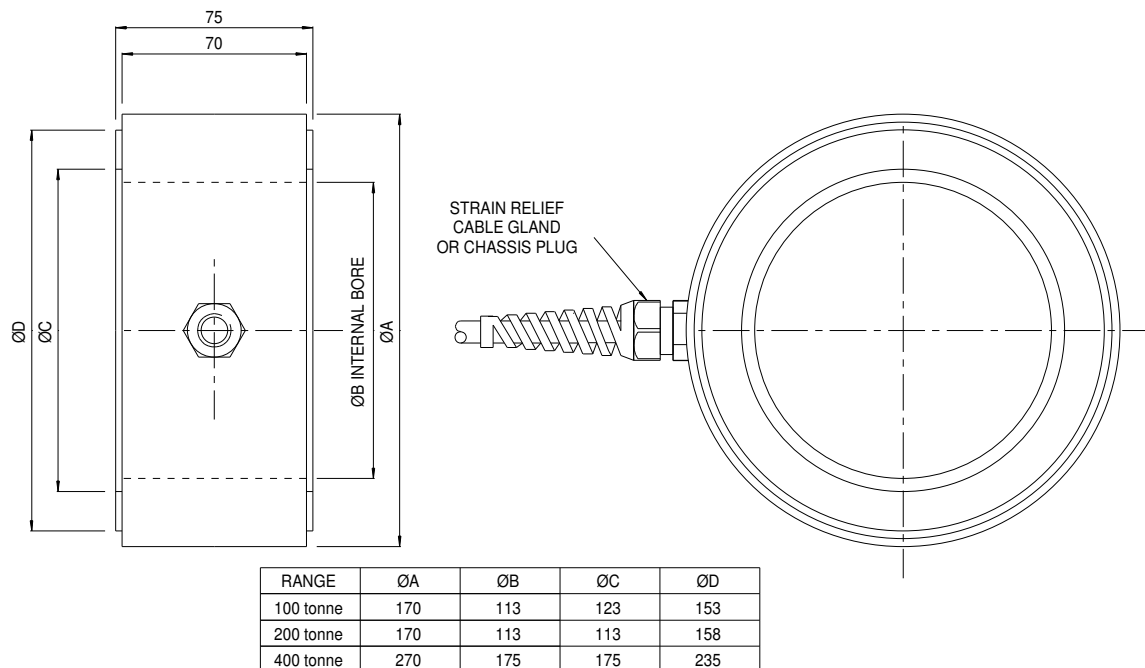

Novatech reserves the right to vary the foregoing details without prior notice

08/2007

NOVATECH MEASUREMENTS LTD

83 CASTLEHAM ROAD, ST LEONARDS ON SEA, EAST SUSSEX, TN38 9NT, ENGLAND

Tel: 01424 852744

email: info@novatechloadcells.co.uk

Fax: 01424 853002

www.novatechloadcells.co.uk